

INSTALLATION MANUAL

DCH3416

Installation Manual



IMPORTANT SAFETY INSTRUCTIONS

- Read these instructions.
- Keep these instructions.
- Heed all warnings.
- Follow all instructions.
- Do not use this apparatus near water.
- The apparatus shall not be exposed to dripping or splashing and no objects filled with liquids, such as vases, shall be placed on the apparatus.
- Clean only with dry cloth.
- Do not block any ventilation openings. Install in accordance with the manufacturers instructions.
- Do not install near any heat sources such as radiators, heat registers, stoves, or other apparatus (including amplifiers) that produce heat.
- Do not defeat the safety purpose of the polarized or grounding-type plug. A polarized plug has two blades with one wider than the other. A grounding type plug has two blades and a third grounding prong. The wide blade or the third prong is provided for your safety. If the provided plug does not fit into your outlet, consult an electrician for replacement of the obsolete outlet.
- Protect the power cord from being walked on or pinched particularly at plugs, convenience receptacles, and the point where they exit from the apparatus.
- Only use attachments/accessories specified by the manufacturer.
- Unplug this apparatus during lightning storms or when unused for long periods of time.
- Refer all servicing to qualified service personnel. Servicing is required when the apparatus has been damaged in any way, such as the power-supply cord or plug is damaged, liquid has been spilled or objects have fallen into the apparatus, the apparatus has been exposed to rain or moisture, does not operate normally, or has been dropped.

IMPORTANT SAFETY CONSIDERATIONS

The DCH3416 requires careful handling to avoid potential damage to its internal hard disk drive or the loss of recorded data. Be sure to follow these requirements during transportation and installation.

The plug is the mains disconnect device. It shall remain readily accessible and operable.

DURING TRANSPORTATION TO THE SUBSCRIBER HOME

Transport the cable terminal in its shipping box or an equally padded container.

Do not expose the terminal to rain or moisture.

DURING INSTALLATION

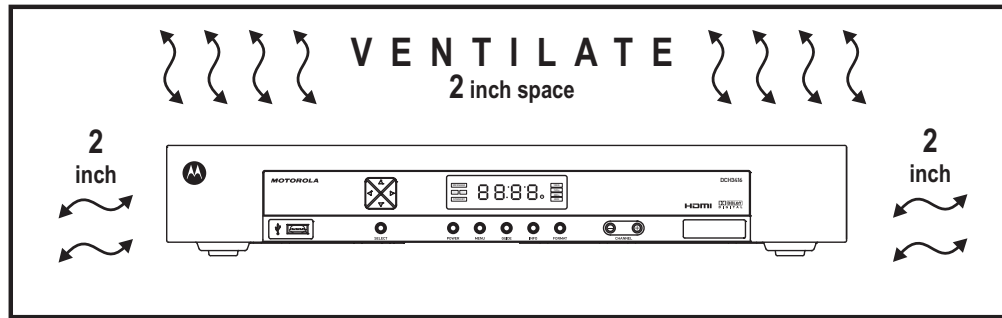

- Do not place the cable terminal in an enclosed area where the cooling vents are blocked or impede the flow of air through the ventilation openings.
- Install the terminal so that its position does not interfere with its proper ventilation. For example, do not place the terminal on a bed, sofa, rug, or similar surface that could block the ventilation openings.
- Install the terminal away from heat sources such as radiators, heat registers, and stoves. Installation of the terminal near consumer electronics devices, such as stereo receiver/amplifiers and televisions, is permitted as long as the air surrounding the terminal does not exceed 40° C (104° F).
- Place the terminal on a flat surface not prone to vibration or impact.
- Do not install the terminal in an area where condensation occurs.
- To prevent the temporary loss of guide data and cause a temporarily non-responding terminal, do not plug the AC power cord into a switched power outlet.
- To avoid shock and vibration damage to the internal hard drive, do not move the terminal while it is plugged in.
- To allow the hard drive to spin down and park its heads, wait at least 10 seconds after disconnecting power before moving the terminal.

FCC COMPLIANCE

Note: This equipment has been tested and found to comply with the limits for a Class B digital device, pursuant to part 15 of the FCC Rules. These limits are designed to provide reasonable protection against harmful interference in a residential installation. This equipment generates uses and can radiate radio frequency energy and, if not installed and used in accordance with the instructions, may cause harmful interference to radio communications. However, there is no guarantee that interference will not occur in a particular installation. If this equipment does cause harmful interference to radio or television reception, which can be determined by turning the equipment off and on, the user is encouraged to try to correct the interference by one or more of the following measures:

- Reorient or relocate the receiving antenna.
- Increase the separation between the equipment and receiver.
- Connect the equipment into an outlet on a circuit different from that to which the receiver is connected.
- Consult the dealer or an experienced radio/TV technician for help.

Caution: Changes or modifications not expressly approved by Motorola for compliance could void the user's authority to operate the equipment.

This device complies with part 15 of the FCC Rules. Operation is subject to the following two conditions: (1) This device may not cause harmful interference, and (2) this device must accept any interference received, including interference that may cause undesired operation.

FCC DECLARATION OF CONFORMITY

Motorola Inc., Connected Home Solutions, 101 Tournament Drive, Horsham, PA 19044, 1-215-323-1000, declares that the DCH3416 receiver complies with 47 CFR Parts 2 and 15 of the FCC rules as a Class B digital device.

CANADA INDUSTRY CANADA (IC)

This Class B digital device complies with Canadian ICES-003.

Cet appareil numérique de la classe B est conforme à la norme NMB-003 du Canada.

Caring for the Environment by Recycling



When you see this symbol on a Motorola product, do not dispose of the product with residential or commercial waste.

Recycling your Motorola Equipment

Please do not dispose of this product with your residential or commercial waste. Some countries or regions, such as the European Union, have set up systems to collect and recycle electrical and electronic waste items. Contact your local authorities for information about practices established for your region. If collection systems are not available, call Motorola Customer Service for assistance.

© 2007 Motorola, Inc. All rights reserved. No part of this publication may be reproduced in any form or by any means or used to make any derivative work (such as translation, transformation, or adaptation) without written permission from Motorola, Inc.

MOTOROLA and the Stylized M logo are registered in the US Patent and Trademark Office. CableCARD™, M-Card™, and DOCSIS® are trademarks or registered trademarks of Cable Television Laboratories, Inc. HDMI is a trademark of HDMI Licensing LLC. Manufactured under license from Dolby Laboratories. "Dolby," "Pro Logic," and the double-D symbol are trademarks of Dolby Laboratories. Macrovision is a registered trademark of Macrovision Corporation. All other product or service names are the property of their respective owners. All rights reserved.

Motorola reserves the right to revise this publication and to make changes in content from time to time without obligation on the part of Motorola to provide notification of such revision or change. Motorola provides this guide without warranty of any kind, implied or expressed, including, but not limited to, the implied warranties of merchantability and fitness for a particular purpose. Motorola may make improvements or changes in the product(s) described in this manual at any time.



CONTENTS

1 Introduction	1
Features	1
Tuners.....	1
Standard Audio/Video Features.....	2
Standard DVR Functionality.....	2
Standard Data Features	3
Standard Miscellaneous Features	3
If You Need Help	4
Calling for Repairs	4
2 Overview	5
Front Panel.....	5
Front Panel Format Button	5
Rear Panel	7
M-Card™.....	7
3 Installation	9
Before You Begin.....	9
Clearing the Hard Drive.....	9
Video Connection Options	10
Audio Connection Options	10
Installation Overview	11
Cabling to an HDTV for Video	12
Cabling to an HDTV and an A/V Receiver.....	13
Cabling to a Standard-Definition TV and an A/V Receiver.....	14
Cabling to a Standard-Definition TV and Audio Receiver	15
Data Device Connections.....	16
Operational Check for the Remote Control.....	17
Optimizing the High-Definition Settings	17
Graphics Overlaying the Video.....	20
4 Diagnostics.....	21
Using the Diagnostics.....	21
General Status	22
Purchase Status	24
Out-Of-Band (OOB) Status	25
Agile OOB Tuner Hunting.....	27
Summary of Manual Selection of the OOB Frequency (OSD Frequency Override in Hunted Mode).....	27

CONTENTS

In-Band Status	28
Unit Address	30
Separable Security	32
Current Channel Status	33
RF Modem (Upstream)	36
Code Modules	38
Memory Configuration	41
Audio/Video Status	42
Interface Status	45
User Setting Status	48
DVR/Hard Drive Status	50
DOCSIS Status	52
Application Specific Information	55
Interactive Status	56
Keypad — Front Panel Indicators	58
5 Troubleshooting	59

Figures

Figure 1-1 Front and rear views	1
Figure 2-1 Front panel	5
Figure 2-2 Rear panel	7
Figure 3-1 Cabling to an HDTV	12
Figure 3-2 Cabling to an HDTV and an A/V receiver	13
Figure 3-3 Cabling to a Standard-Definition stereo TV	14
Figure 3-4 Cabling an audio receiver	15
Figure 3-5 Sample data devices you can connect to the DCH3416	16
Figure 4-1 Example of the front panel display for the diagnostic main menu	21
Figure 4-2 Example General Status display (no error)	22
Figure 4-3 Front panel display for Purchase Status diagnostic	24
Figure 4-4 Front panel display for the OOB diagnostic	26
Figure 4-5 Front panel display for in-band diagnostic	29
Figure 4-6 Front panel display of a unit address	30
Figure 4-7 Current channel status front panel displays	34
Figure 4-8 RF upstream modem front panel display	37
Figure 4-9 Front panel display for code modules	39
Figure 4-10 Interactive status front panel display	56

CONTENTS

Tables

Table 1-1 DVR Recording Time Guidelines.....	3
Table 2-1 Front panel	5
Table 2-2 Rear panel connections.....	7
Table 3-1 Operational check procedures.....	17



1 INTRODUCTION

This manual provides instructions for cable operator personnel to install the Motorola DCH3416 All-Digital High-Definition Dual Tuner DVR Cable Receiver. This unit includes a high-end processor, expanded memory, and enhanced graphics to support digital and on-demand broadcast and interactive services. It provides a full complement of interconnection options.

The DCH3416 provides advanced capabilities, including:

- Authorization and purchase of on-demand programming
- High-Definition television (HDTV) video decoding
- HDTV output through component video (YPbPr), High-Definition Multimedia Interface™ (HDMI™), or IEEE-1394
- Surround-sound audio through a variety of analog and digital interconnection options
- Dual-tuner DVR functionality to pause and time shift live video and seamlessly record in conjunction with the Interactive Programming Guide (IPG)
- Built-in DOCSIS® cable modem
- Ethernet and Universal Serial Bus (USB) 2.0 ports for future home networking applications
- Adaptability to various software platforms

As with all Motorola digital cable receivers, the hardware features are enabled by core operating and third party application software.

Figure 1-1 Front and rear views

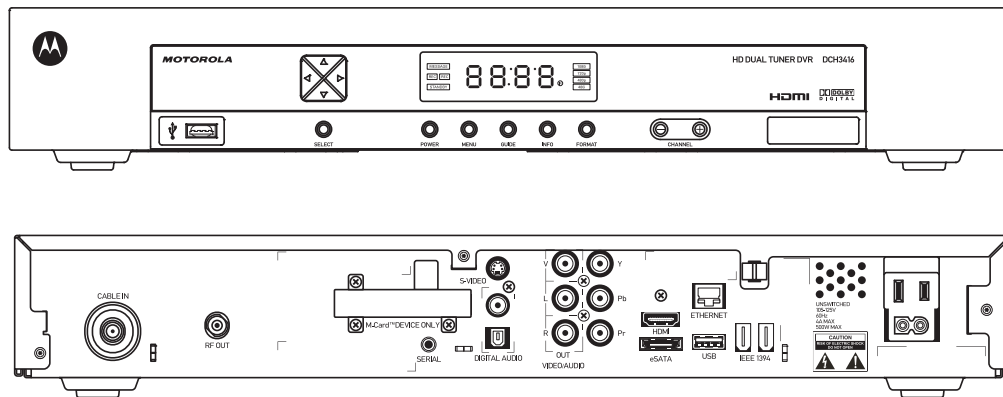

Features

Tuners

- Two 54 to 864 MHz video tuners with digital MPEG-2 Main Profile @ High Level (High-Definition) video processor

1 INTRODUCTION

- One dedicated tuner for the DOCSIS high-speed data/voice services channel, up to 860 MHz
- One dedicated tuner for the out-of-band (OOB) control channel

Standard Audio/Video Features

- ITU standard 64/256 QAM/FEC/enhanced adaptive equalizer
- DES based encryption/DCII (via inserted CableCARD™) access control
- Out-of-band data receiver (70-130 MHz) 2.048 Mbps
- Digital video scaling (picture in graphics)
- 32-bit 2D graphics support in hardware
- Macrovision® copy protection
- High-Definition video output through:
 - HDMI (also compatible with DVI using an HDMI-to-DVI converter cable)
 - Component Video (YPbPr)
 - IEEE-1394
- Standard-Definition video output through:
 - S-Video
 - Baseband
 - RF
- Audio output through:
 - Digital audio (S/PDIF) ATSC standard Dolby® Digital electrical or optical
 - Baseband L/R

Standard DVR Functionality

- DVR functionality integrated with the IPG enables subscribers to:
 - Pause, rewind, fast-forward, or record live TV
 - Maintain a personal recorded program library and access it using the IPG
 - Select programs to record across multiple channels and time slots
 - Rewind and replay recorded programs
 - Simultaneously watch two programs, switching easily between them using the swap key
 - Record a program in the background while viewing another live program
 - Simultaneously record programs from two channels while watching a different pre-recorded program, with the ability to switch viewing between any of the three programs

1 INTRODUCTION

Motorola cannot guarantee the exact amount of programming that each subscriber will be able to record. The approximate time depends on the programming type and the drive size:

Table 1-1 DVR Recording Time Guidelines

Model	Drive Size	Estimated Recording Hours For:	
		Standard Digital Channels	HDTV Channels
DCH3416	160 GB	55 to 100	14 to 21

All times are approximate. The actual hours a subscriber can record are a function of program bit rate, the IPG type, and the reserved buffer space.

Standard Data Features

- Integrated DOCSIS 1.0/1.1/2.0 capable cable modem
- 16 MB flash memory (supports up to 32 MB optional)
- 128 MB SDRAM (256 MB optional)
- One rear and one front Universal Serial Bus (USB) 2.0 port (dual connector interface)
- One eSATA (external SATA) connector, un-powered for data-only.
- 10/100 Mbps Ethernet Port (RJ-45)
- On-board real-time RF return (DOCSIS compliant)

Standard Miscellaneous Features

- Unswitched AC accessory outlet
- Messaging capabilities
- Digital diagnostics
- Full feature access from front panel using a four-digit, seven-segment VFD display

1 INTRODUCTION

If You Need Help

If you need assistance while working with the DCH3416, contact the Motorola Technical Response Center (TRC):

- Inside the U.S.: 1-888-944-HELP (1-888-944-4357)
- Outside the U.S.: 1-847-725-4011
- Motorola Online: <http://businessonline.motorola.com/>

The TRC is on call 24 hours a day, 7 days a week. In addition, Motorola Online offers a searchable solutions database, technical documentation, and low-priority issue creation and tracking. For specific toll-free numbers when calling from outside the United States, please refer to your product manual or our Web page.

Calling for Repairs

If a Motorola set-top requires repair service, please call one of the following Motorola Authorized Service Centers:

Company	From USA or Canada	Outside USA or Canada
World Wide Digital	1-800-227-0450	1-956-541-0600
Teleplan	1-800-352-5274	1-302-322-6088

To ensure efficient service, request a Return for Service Authorization (RSA) number. Be sure to display the RSA number prominently on all equipment boxes.

The Service Center will provide the shipping address of the location performing your repairs.

To ship your equipment for repair:

- Pack the unit securely, if possible in its original factory shipping carton.
- Print or display the RSA number so it is easily visible on all equipment boxes.
- Enclose a note describing the exact problem. Complete and enclose the checklist provided with the unit.
- Ship the unit PREPAID to the address provided by the Service Center.



2 OVERVIEW

Front Panel

The front panel controls provide functional navigation if the remote control is lost or is temporarily out of service. Certain functions, such as those requiring a numeric entry, require a remote control. Some connectors are not enabled and require the support of application software.

Figure 2-1 Front panel

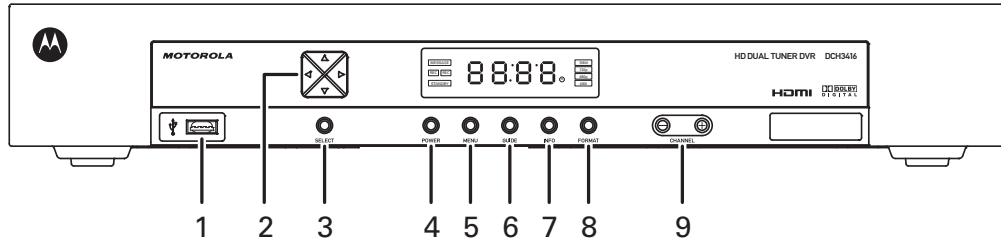

Table 2-1 Front panel

1	USB connector
2	Cursor — menu navigation
3	Select — selects menu options
4	Power — turns the receiver on and off (standby)
5	Menu — displays the menu
6	Guide — displays the program guide
7	Info — displays current channel and program information
8	Format* — change the video output format
9	Channel — changes channel up or down

**The availability of certain features is dependent upon application support.*

Front Panel Format Button

The Format button* located on the front panel of the DCH3416 allows you to quickly change the video output format on the Component Video (YPbPr) and HDMI outputs of the product. The DCH3416 is capable of providing the following video formats on the YPbPr and HDMI video outputs:

- High Definition 1080i (1920 x 1080 pixels)
- High Definition 720p (1280 x 720 pixels)
- Enhanced Definition 480p (720 x 480 pixels)
- Standard Definition 480i (720 x 480 pixels)

2 OVERVIEW

The Format button is intended to allow you to select a video output format that is compatible with a connected display device. Some televisions may not support all four video formats listed above. The Format button provides an easy method for selecting an output format that is compatible with your television.

Operation

The Format button is intended to complement the User Settings Menu (see [User Setting Status](#)). It is not intended to replace the User Settings Menu. The User Settings Menu is the preferred method of optimizing the DCH3416 to operate with your specific television.

If you cannot get a video display when the DCH3416 is connected to your television via Component Video or HDMI cables, use the Format button to select a video output format that results in a viewable picture on the display screen. Once a viewable picture is available, please use the User Settings Menu to optimize the DCH3416 display settings for your specific television.

Video Format Indicators (Front Panel Display)

The front panel display of the DCH3416 is equipped with four indicators to the right hand side of the display that are used to indicate the currently-selected video output format on the Component Video (YPbPr) and HDMI outputs. As the Format button is depressed, the front panel format indicators will change to illuminate the currently selected video output format in use by the DCH3416.

Note: There are some scenarios where the DCH receiver does not change the video output format if the Format button is depressed. In these scenarios, the DCH3416 will flash the currently illuminated video format indicator on the front panel display. If this should occur, please use the User Settings Menu to make further changes to the video output settings of the DCH3416 receiver.

**The availability of certain features is dependent upon application support.*

2 OVERVIEW

Rear Panel

The rear panel contains an unswitched power outlet; connectors for video, audio, and RF cabling; data output; and modem and data interface connectors. Some connectors are not enabled and require the support of application software.

Figure 2-2 Rear panel

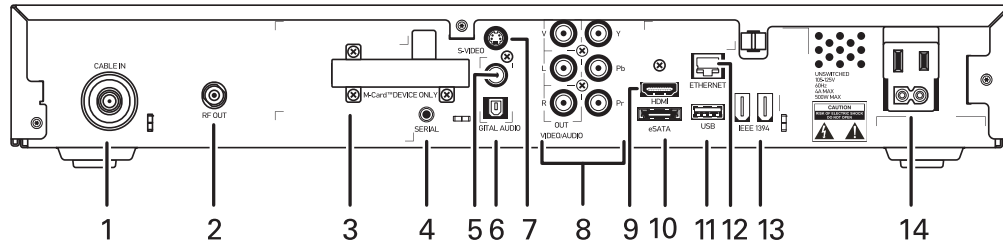

Table 2-2 Rear panel connections

1	Cable In — Connects to cable signal from your service provider
2	RF Out — Ch 3/4 modulated audio/video (SDTV) to TV or VCR
3	M-Card — Inserted M-Card
4	Serial — Service only
5-6	Digital Audio (S/PDIF) — Provides Dolby® Digital 5.1 audio or PCM output
7	S-Video — Connects to S-Video (SDTV) input of TV or VCR
8	Video/Audio—Composite Video (SDTV) /Audio L/R outputs / YPbPr— Component video output (HDTV)
9	HDMI — High-Definition TV (HDTV) connector
10	eSATA* — External Serial ATA disk interface
11	USB* 2.0 — High-Speed peripheral device connection
12	Ethernet* — Network connection
13	IEEE-1394 — Audio and video device connection
14	Power cord connector

**The availability of certain features is dependent upon application support.*

M-Card™

The M-Card is required to view cable television programs, previously recorded programs on the DVR, or interactive on-demand programs. The M-Card should not be removed.



3 INSTALLATION

Before You Begin

Before you move or change components on the subscriber's entertainment system:

- Review the installation instructions.
- Determine if you are connecting to a standard analog NTSC TV (supporting an RF input), a composite (baseband) video input, or an S-Video input) or a High-Definition TV (supporting component video input, HDMI input, or an IEEE-1394 input).
- Determine if the subscriber has other equipment to be connected to the terminal (home theater or A/V receiver, VCR, etc.)
- Verify that you have the necessary cables and other required items.
- If the terminal was previously used, clear its hard drive before installing it at a new subscriber location

Clearing the Hard Drive

On a previously-used cable terminal, delete all recorded programs from the hard drive before installing it at a new subscriber location. This prevents your new subscriber from viewing programming they may not have purchased or may not want to see.

To prevent subscribers from accidentally deleting all of their recorded programs, a specific set of keystrokes is required to clear the hard drive. Having a TV connected is optional.

To clear the hard drive:

1. Start the diagnostics as described in the [Diagnostics](#) section; *d 01* is displayed on the front-panel display.
2. Using a remote control, within five seconds, press REPLAY, MY DVR three times, and LIVE TV. (On some remote controls, the MY DVR key may be labeled LIST.)
3. If you correctly enter this key sequence in five seconds or less, the hard drive is cleared and the front-panel displays *Clr*.
4. If *Clr* is not displayed, re-enter the key sequence in step 2.
5. If *Clr* is displayed, press any other key to reset the terminal, turn it off, and complete the clearing process.

3 INSTALLATION

Video Connection Options

Use the following guidelines to determine the best video connection for the subscriber home entertainment system. To determine the available video inputs on the TV, check the manual supplied with the TV or the TV itself.

The DCH3416 offers the following video outputs:

Component (YPbPr)	HDTV and SDTV	The YPbPr outputs provide component video, the most widely supported HD video connection.
HDMI or IEEE-1394	HDTV and SDTV	HDMI and IEEE-1394 offer higher-quality HD video than component video. If the TV has an HDMI or a DVI input, use the HDMI output instead of the IEEE-1394 output. HDMI and IEEE-1394 are video and audio connections. If you use HDMI or IEEE-1394, no separate audio connection to the TV is required. HDMI is compatible with DVI. If the TV has a DVI input, you can use an HDMI-to-DVI converter cable or adapter to connect to the DCH3416 HDMI connector. If you use IEEE-1394, on-screen graphics do not display.
S-Video	SDTV only	If your TV has an S-Video input, use S-Video. S-Video is the highest-quality Standard-Definition video output on the DCH3416.
Video (composite)	SDTV only	If your TV does not have an S-Video input, use the composite video (video) output.
RF	SDTV only	If your TV only has a coaxial RF input, connect it to the DCH3416 RF out connector.

Audio Connection Options

When connecting to a home theater receiver, depending on its inputs, you can use the following DCH3416 audio outputs:

Digital audio optical (S/PDIF) or digital audio coaxial (S/PDIF)	If the receiver supports it, use the digital audio optical (S/PDIF) or digital audio coaxial (S/PDIF) audio output to deliver Dolby Digital audio to a Dolby Digital home theater receiver. <ul style="list-style-type: none">For an HDMI or IEEE-1394 video connection, no additional audio connections to the TV are required.For RF output, no further audio connection is required.
Baseband Audio L and R	If the audio receiver does not support Dolby Digital, use the baseband AUDIO L and R outputs to connect to the audio receiver.

Connect the stereo audio cable to the AUDIO L and R connectors on the DCH3416 and the audio left and right connectors on the TV. If the equipment supports it, use the optical SPDIF or coaxial digital SPDIF output instead of the AUDIO L and R outputs. In most cases, these outputs offer better audio quality, including support for 5.1 Surround Sound.

The cabling diagrams show sample audio/video (A/V) connections to an audio receiver, where the receiver functions as an A/V router. When connecting to an audio receiver, reference its installation instructions for directions on connecting to baseband and digital audio (S/PDIF) ports.

3 INSTALLATION

The VCR and TV receive their AV signals from the currently selected input device on the audio receiver. This is important when the subscriber has another AV device such as a DVD player, a secondary VCR, a CD player, or other electronic component. We recommend connecting the TV to the monitor output so on-screen menus for the receiver can be displayed. (In many cases, the receivers themselves have interactive on-screen menus.)

Installation Overview

1. Determine if you are connecting to a:

High-Definition TV or monitor	Use the component video (YPbPr), HDMI, or IEEE-1394 outputs. No other video connection supports HDTV. If your TV has a DVI input, connect a DVI-to-HDMI adapter or cable to the HDMI out connector on the DCH receiver instead of the IEEE-1394 connection and the DVI-HDTV connector on your TV.
Standard-Definition TV	Connect the S-Video connector using an S-video cable or connect the composite video connector using a composite (RCA phono) cable. If the TV only has a coaxial RF input, connect it to the DCH3416 RF OUT connector.

2. Determine if you are connecting the audio to a home theater receiver or directly to the TV:
 - For an HDMI or IEEE-1394 video connection, no additional audio connections to the TV are required.
 - If the receiver or TV has a digital audio (S/PDIF) input, use the digital audio OPTICAL (S/PDIF) or COAXIAL (S/PDIF) outputs.
 - Otherwise, use the baseband left and right audio out outputs.
3. Locate the cabling diagram(s) that best match the subscriber's configuration.
4. Connect the audio and video cables in a manner matching that diagram.
5. Determine if you are connecting to a data device (see [Data Device Connections](#) in this section). For installation details, refer to the instructions included with the data device.
6. Connect the cable terminal to the coaxial cable wall outlet.
7. Perform the operational check for the remote control.
8. Optimize the High-Definition settings. See [Optimizing the High-Definition Settings](#) in this section.

3 INSTALLATION

Cabling to an HDTV for Video

For the best possible HDTV video quality:

- If the TV has an HDMI input, connect it to the DCH3416 HDMI output. If the TV has a DVI input, you can connect it to the DCH3416 HDMI output using an HDMI-to-DVI converter cable or adapter.
- If the TV has neither an HDMI nor a DVI input but has an IEEE-1394 input, connect it to the DCH3416 IEEE-1394 output. If you use IEEE-1394, on-screen graphics do not display.
- Otherwise, use the component video (Y, Pb, and Pr) connectors.

Note: Be sure to match up each signal to the same connection on the TV. Otherwise, the colors will not appear correctly on your TV.

Figure 3-1 Cabling to an HDTV

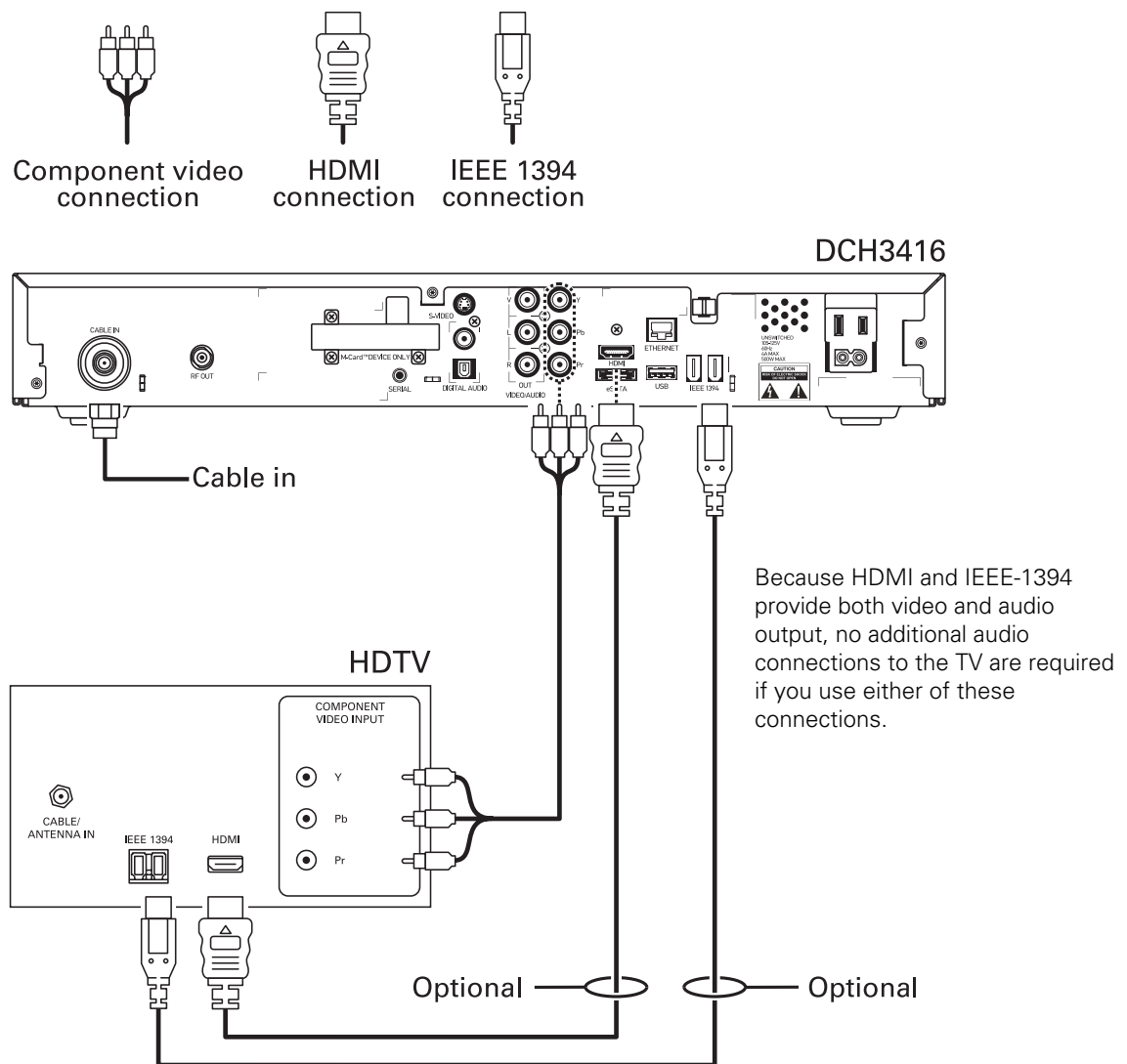

3 INSTALLATION

Cabling to an HDTV and an A/V Receiver

Figure 3-2 Cabling to an HDTV and an A/V receiver

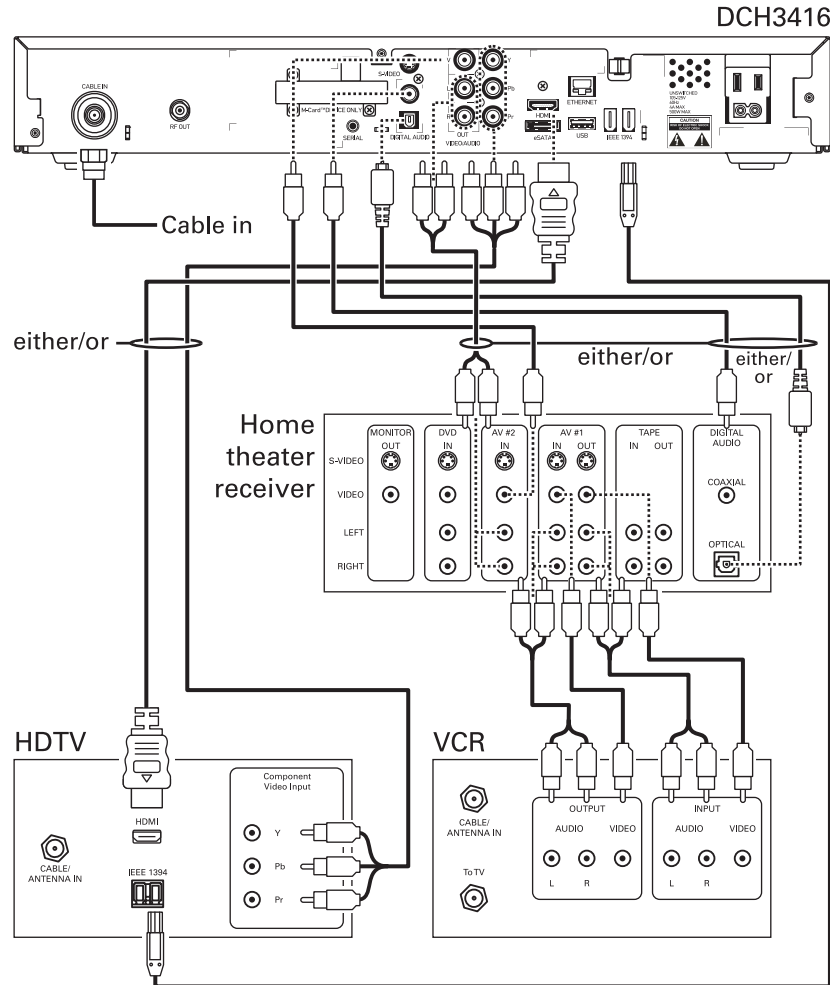
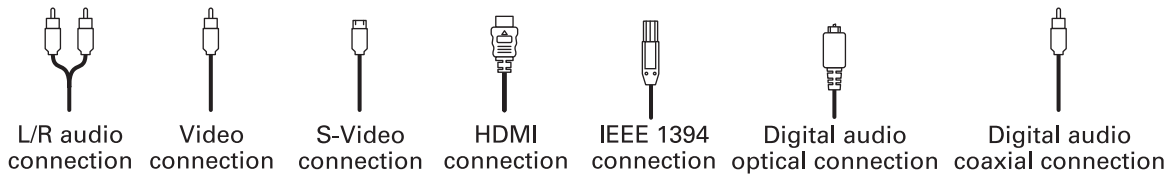

If the receiver can check the baseband and digital audio (S/PDIF) ports for appropriate channels, connect both the baseband and digital audio connections. Otherwise, do not connect both the baseband left/right composite connections and the coaxial digital connection. The baseband connections are not necessary because the digital audio port provides a single audio interface for digital channels.

Note: If the A/V receiver includes HDMI inputs & output(s) then the DCH3416 HDMI output can be directly connected to the A/V receiver.

3 INSTALLATION

Cabling to a Standard-Definition TV and an A/V Receiver

Figure 3-3 Cabling to a Standard-Definition stereo TV

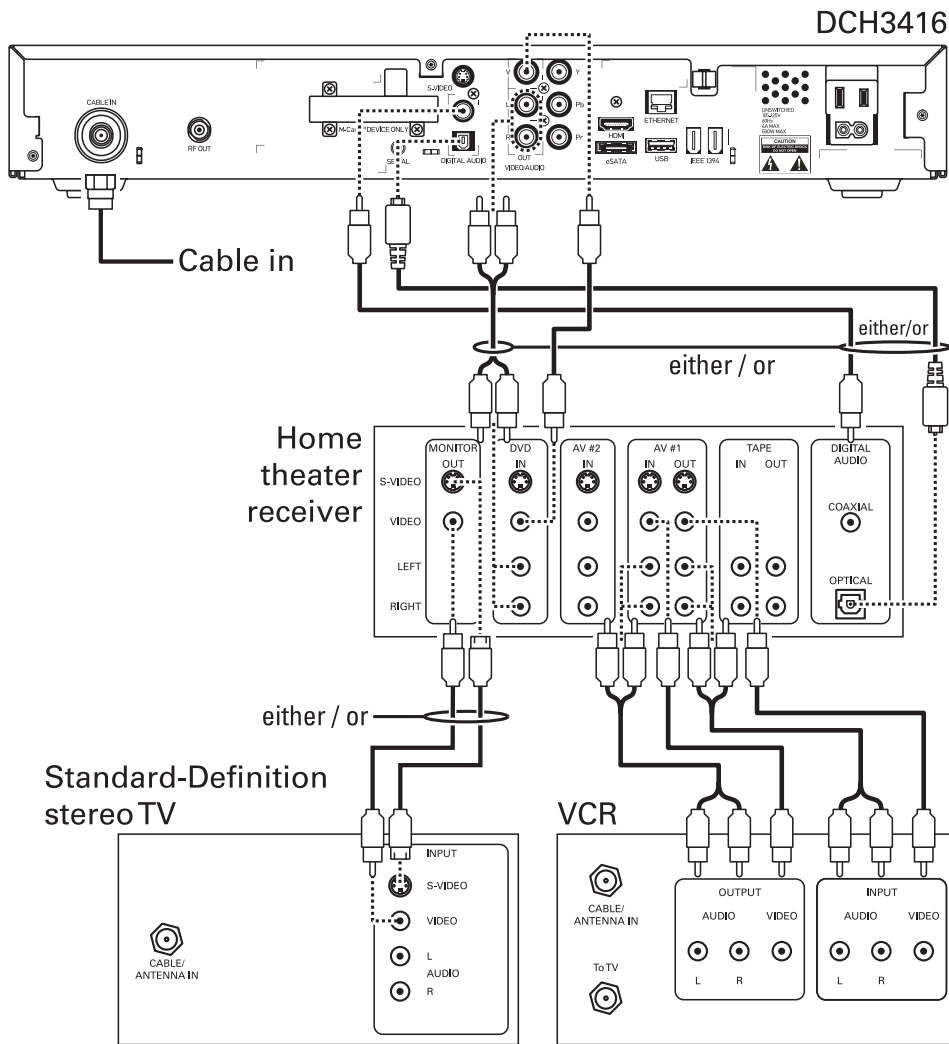
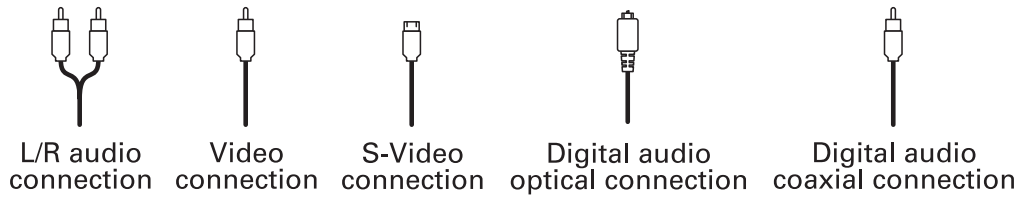

Because some entertainment equipment cannot simultaneously support baseband composite video and S-Video, never simultaneously connect both video inputs.

This connection method does not support HDTV. For information, see [Cabling to an HDTV for Video](#) in this section.

3 INSTALLATION

Cabling to a Standard-Definition TV and Audio Receiver

To connect to an audio receiver, such as a home mini system, use a daisy-chain cabling connection. The A/V configuration illustrated below enables digital stereo recording, including Dolby Digital Surround sound. Use only one set of composite input connectors on the audio receiver:

Figure 3-4 Cabling an audio receiver

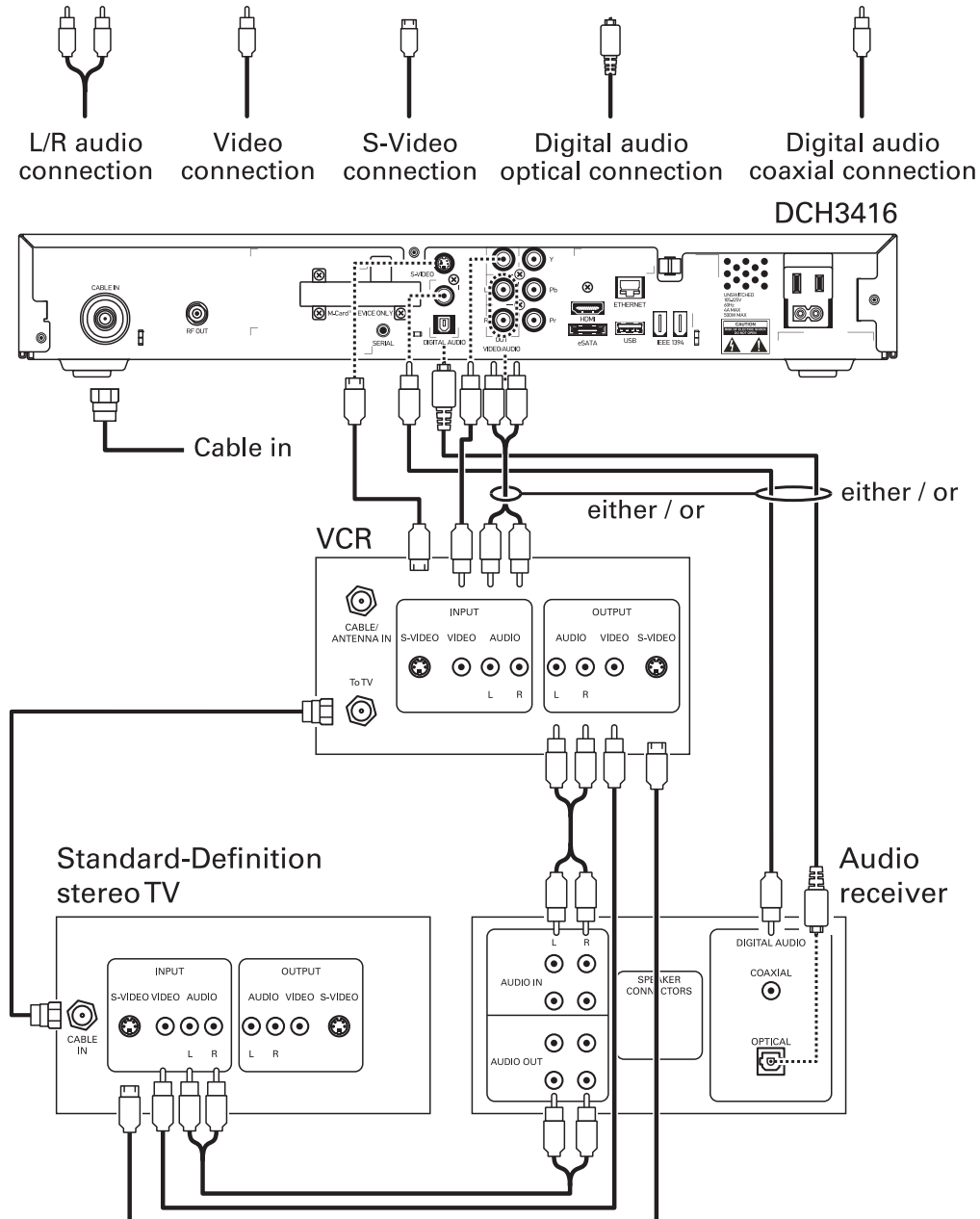

The video connections shown in this illustration do not support HDTV. For HDTV connection information, see [Cabling to an HDTV for Video](#) in this section.

3 INSTALLATION

Data Device Connections

The DCH3416 provides optional high-speed data services such as Internet access, USB, Ethernet, and more. The functionality of each data device port requires, and depends on, installed application software.

The DCH3416 rear panel provides the following data ports:

USB 2.0	Can be used to daisy-chain USB devices such as printers and storage devices, or to interface with keyboards, joysticks, and other USB PC peripherals.
Ethernet	10/100 Mbps RJ-45 port
eSATA	Can be used to connect an external hard drive to increase DVR capacity
IEEE-1394	Can be used to connect an MPEG-2 compatible display device

The DCH3416 front panel provides:

USB 2.0	Can be used in the same manner as the rear panel USB 2.0 port
----------------	---

Figure 3-5 Sample data devices you can connect to the DCH3416

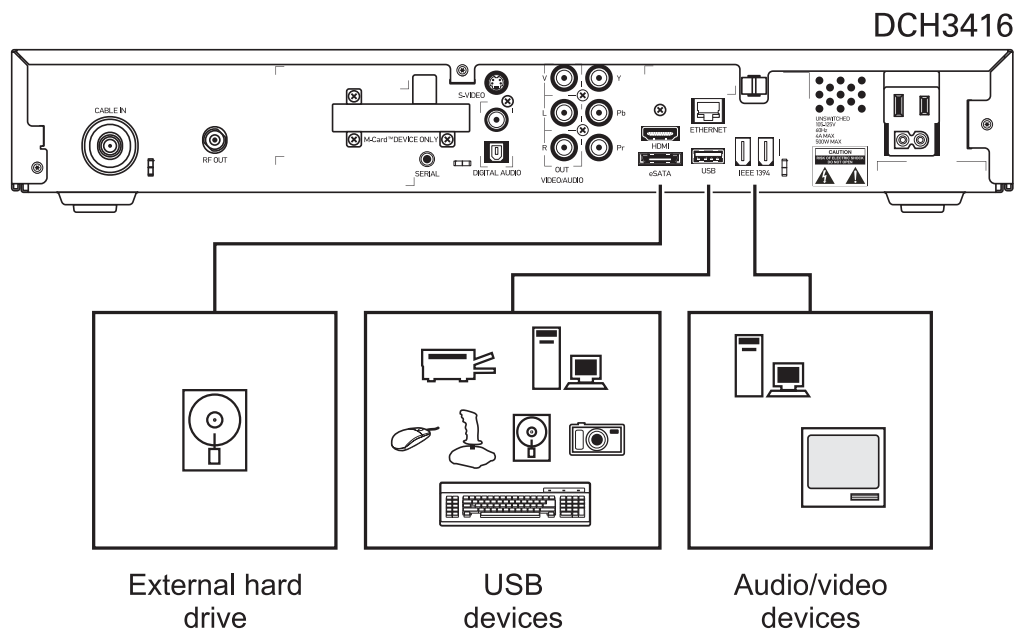

3 INSTALLATION

Operational Check for the Remote Control

The operational check tests communication with the remote control:

Table 3-1 Operational check procedures

Feature	Testing Procedure
Power on	Press POWER on the remote control to turn on the DCH3416. Tune to the output channel (3 or 4) if using the RF output.
Channel selection	Scan through the channels using the CHANNEL + or - keys. Tune to several channels by entering the channel number using the numeric keys.
Volume control	Press VOLUME + or - on the remote control to increase the volume to its upper limit, lowest level, and to a comfortable level. Press MUTE to turn the sound off. Press MUTE again to restore the sound.

If the DCH3416 does not operate properly, refer to the [Troubleshooting](#) section.

Optimizing the High-Definition Settings

This subsection describes how to optimize SD and HD video settings and closed captioning based on subscriber preferences.

Before you optimize the output settings:

- Connect the DCH3416 receiver to other home entertainment devices
- Plug the DCH3416 receiver into a power outlet
- Initialize the DCH3416 receiver and authorize services
- Turn the TV on

For an HDMI connection, be sure the TV is on and connected to the HDMI connector before adjusting the settings. Motorola recommends using HDMI cables less than 20 meters long.

To optimize the output settings:

1. Power off the DCH3416 and then immediately press the MENU key on the front panel. If the TV is on, the on-screen menu lists the settings you can configure:

3 INSTALLATION

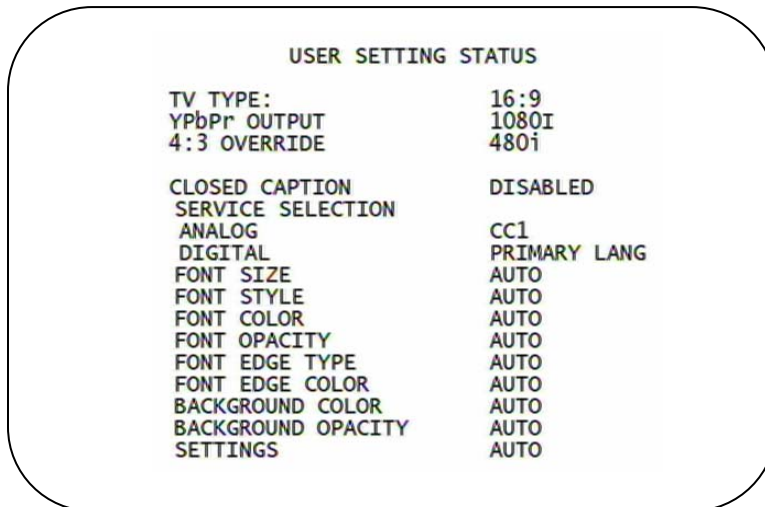

2. Use the remote control or the cursor keys on the front panel to navigate the on-screen menus:
 - Press the ▲ and ▼ keys to highlight the setting you wish to change.
 - Press the ► key to select an option.
 - To exit the setting and move to another setting, press the ▲ or ▼ key.

If the User Settings menu does not display on the HDTV screen, the TV may not support the default video output setting. Use the front panel display to adjust the settings as described in “There is no video on the TV screen” in the [Troubleshooting](#) section.

The User Settings menu options are:

Setting	Description
TV Type	<p>Allows you to specify the style of television connected to the DCH receiver. Options include 16:9, 4:3 LETTERBOX, and 4:3 PAN SCAN. By default, the 16:9 option is selected. The options are used as follows:</p> <ul style="list-style-type: none"> • 16:9 designates that a widescreen television is connected to the DCH receiver. • 4:3 LETTERBOX designates that a standard-screen television is connected to the DCH receiver and that widescreen programs should be scaled to fit the screen with black bars above and below the picture. • 4:3 PAN SCAN designates that a standard-screen television is connected to the DCH receiver and that widescreen programs should be cropped so that the picture fills the entire screen.

3 INSTALLATION

Setting	Description
HDMI/YPbPr Output	<p>Allows you to specify the video output format of the DCH receiver for all content (when the 4:3 override setting is Off) or for all 480p, 720p, and 1080i content (when the 4:3 override is used). Options include 1080i, 720p, 480p, and 480i. By default, the 1080i option is selected. The options are used as follows:</p> <ul style="list-style-type: none"> • 1080i — The DCH receiver will present programs in the High-Definition 1080i format (1920 x 1080 pixels). • 720p — The DCH receiver will present programs in the High-Definition 720p format (1280 x 720 pixels). • 480p — The DCH receiver will present programs in the Enhanced-Definition 480p format (720 x 480 pixels). • 480i — The DCH receiver will present programs in the Standard-Definition 480i format (720 x 480 pixels). <p>Some televisions may only support certain video formats. Please consult your television's user manual for more information on format compatibility.</p> <p>The DCH receiver can detect when the HDMI connection is in use. If you are not using the HDMI connection on the DCH receiver, the HDMI/YPbPr Output setting will display as YPbPr Output in the User Settings Menu.</p>
4:3 Override	<p>The 4:3 Override setting allows you to specify the video output format of the DCH receiver when it is tuned to a Standard-Definition program or playing back a Standard-Definition program from the DVR. Options include 480i, 480p, Stretch, and Off. By default, the 480i option is selected. The options are used as follows:</p> <ul style="list-style-type: none"> • 480i — The DCH receiver will present Standard-Definition programs in the Standard-Definition 480i format (720 x 480 pixels). • 480p — The DCH receiver will present Standard-Definition programs in the Enhanced-Definition 480p format (720 x 480 pixels). • Stretch — The DCH receiver will automatically stretch all Standard-Definition programs to a widescreen aspect ratio and present the video in the format designated by the HDMI/YPbPr Output setting. Note that the Stretch option is only available when the TV Type setting is 16:9. • Off — The DCH will create a widescreen version of a Standard-Definition program by adding black bars to the left and the right of the picture and present the video in the format designated by the HDMI/YPbPr Output setting. <p>Some televisions may only support certain video formats. Please consult your television's user manual for more information on format compatibility.</p> <p>If the HDMI/YPbPr Output setting is 480i, the 4:3 Override feature is disabled and is no longer selectable in the menu. The 4:3 Override feature is available when the HDMI/YPbPr Output setting is 1080i, 720p, or 480p.</p>
Closed Caption	<p>Turns closed captions off or on. The front panel display indicates the status of the closed captions. Defaults to DISABLED. Options are ENABLED or DISABLED.</p>
Service Selection	<p>Sets the service used for closed captions:</p> <ul style="list-style-type: none"> • Digital: PRIMARY LANGUAGE, SECONDARY LANGUAGE, 3, 4, 5, or 6. The default is PRIMARY LANGUAGE.
Font Size	<p>Sets the font size for closed captions. Defaults to AUTO. Options are AUTO, STANDARD, LARGE, or SMALL.</p>
Font Style	<p>Sets the font style for closed captions. Defaults to AUTO. Options are AUTO, MONO SERIF, PROPORTION SERIF, MONO NO SERIF, PROPORTION NO SERIF, CASUAL, CURSIVE, or SMALL.</p>
Font Color	<p>Sets the font color. Defaults to AUTO. Options are AUTO, WHITE, BLACK, RED, GREEN, BLUE, YELLOW, MAGENTA, or CYAN.</p>

3 INSTALLATION

Setting	Description
Font Opacity	Sets the opacity. Defaults to AUTO. Options are AUTO, TRANSPARENT, TRANSLUCENT, SOLID, or FLASHING.
Font Edge Type	Sets the edge appearance — AUTO, NONE, RAISED, DEPRESSED, UNIFORM, LEFT SHADOWED, or RIGHT SHADOWED. The default is AUTO.
Font Edge Color	Sets the edge color — AUTO, WHITE, BLACK, RED, GREEN, BLUE, YELLOW, MAGENTA, or CYAN. The default is AUTO.
Background Color	Sets the background color for closed captions. Defaults to AUTO. Options are AUTO, WHITE, BLACK, RED, GREEN, BLUE, YELLOW, MAGENTA, or CYAN.
Background Opacity	Sets the background opacity for closed captions. Defaults to AUTO. Options are AUTO, TRANSPARENT, TRANSLUCENT, SOLID, or FLASHING.
Settings	Sets the default settings for closed captions (AUTO) or the settings you have configured (USER). Defaults to AUTO. Options are AUTO or USER.
Restore All Defaults	To reset all User Settings to their defaults, select this option and press the ► key.

3. To exit the menu and save your settings, press the power or menu key.

Graphics Overlaying the Video

The DCH3416 can generate graphics that overlay the video programming or fill the entire television screen. Common examples include on-screen menus (such as the User Setting menu), closed captions, and IPG. The DCH3416 overlays these graphics whenever you open a menu, enable closed captions, or scroll through a program grid.

On-screen graphics are available for all DCH3416 video outputs except IEEE-1394.



4 DIAGNOSTICS

Diagnostics are displayed on the on-screen display (OSD) and front-panel display. They confirm proper installation, including:

- Checking error states and signal integrity
- Identifying the cable terminal on the network
- Verify communications with the headend

For the diagnostics described in this section:

- All indicators are in decimal notation, unless otherwise noted.
- All signal-level and quality indicators use a 1% to 100% scale, unless otherwise noted.
- All sample displays are illustrative; actual data may differ from the examples.

Using the Diagnostics

To use the diagnostics:

1. Ensure that the DCH3416 is installed with the Thin Client software and that it is connected to an AC outlet.
2. Press POWER and immediately press SELECT to enable diagnostic mode. The Diagnostics main menu is displayed on the OSD and "d01" is displayed on the front panel:

Figure 4-1 Example of the front panel display for the diagnostic main menu



You can use the following keys to navigate the diagnostics menus:

- Press channel ▲, channel ▼, cursor ▲, or cursor ▼ to select d01 through E.
- Press cursor ◀, cursor ▶, select or enter to execute the selected diagnostic.
- Select E from the main menu or press power to exit.

4 DIAGNOSTICS

General Status

This diagnostic displays system status information on the OSD and front panel. The information is updated each time the diagnostic is displayed.

```
DIAGNOSTICS
> d01 GENERAL STATUS
d02 PURCHASE/POLL STATUS
d03 OOB STATUS
d04 INBAND STATUS
d05 UNIT ADDRESS/SECURITY
d06 CURRENT CHANNEL STATUS
d07 UPSTREAM STATUS
d08 CODE MODULES
d09 MEMORY CONFIG
d10 AUDIO/VIDEO STATUS
d11 INTERFACE/PORT STATUS
d12 USER SETTING STATUS
d13 DVR/HDD STATUS
d14 DOCSIS STATUS
d15 APPLICATION SPECIFIC INFORMATION
d16 INTERACTIVE STATUS
d17 CONNECTED HOME
d18 KEYPAD/LED
E EXIT
```

```
GENERAL STATUS
ERROR:          EP00 N/A      DES
PLATFORM ID:   0x0200
FAMILY ID:     0x0015
MODEL ID:      0xA730
REMOD CHANNEL: 03
SETTOP TIME:   N/A
DST ACTIVE:    N/A
TIME_ZONE:     N/A
DST ENTRY TIME: N/A
DST EXIT TIME: N/A
CURRENT GPS TIME: N/A
```

Figure 4-2 Example General Status display (no error)

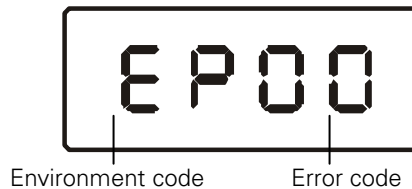

4 DIAGNOSTICS

The General Status fields are:

Field	Description																										
Error	Error codes display on the LED and OSD when an error occurs. If multiple errors occur, the last recorded error is displayed:																										
	<table border="1"> <thead> <tr> <th>Error Code</th> <th>Description</th> </tr> </thead> <tbody> <tr> <td>EP00</td> <td>No error</td> </tr> <tr> <td>EP01</td> <td>Not connected</td> </tr> <tr> <td>EP03</td> <td>DRAM error</td> </tr> <tr> <td>EP04</td> <td>SRAM error</td> </tr> <tr> <td>EP07</td> <td>ROM verification failure</td> </tr> <tr> <td>EP08</td> <td>RAM test failure</td> </tr> <tr> <td>EP09</td> <td>Battery test failure</td> </tr> <tr> <td>EP11</td> <td>Invalid unit address</td> </tr> <tr> <td>EP12</td> <td>Power on self test failure</td> </tr> <tr> <td>EP14</td> <td>GITV startup failure</td> </tr> <tr> <td>EP15</td> <td>TSI structure corrupt</td> </tr> <tr> <td>EP18</td> <td>Driver initialization failure</td> </tr> </tbody> </table>	Error Code	Description	EP00	No error	EP01	Not connected	EP03	DRAM error	EP04	SRAM error	EP07	ROM verification failure	EP08	RAM test failure	EP09	Battery test failure	EP11	Invalid unit address	EP12	Power on self test failure	EP14	GITV startup failure	EP15	TSI structure corrupt	EP18	Driver initialization failure
Error Code	Description																										
EP00	No error																										
EP01	Not connected																										
EP03	DRAM error																										
EP04	SRAM error																										
EP07	ROM verification failure																										
EP08	RAM test failure																										
EP09	Battery test failure																										
EP11	Invalid unit address																										
EP12	Power on self test failure																										
EP14	GITV startup failure																										
EP15	TSI structure corrupt																										
EP18	Driver initialization failure																										
Connected State	A DCH-operations connect or disconnect message determines whether the DCH3416 is CONNECTED or DISCONNECTED.																										
Platform ID	A unique 16-bit hexadecimal number that identifies the platform image (also called the ROM ID).																										
Family ID	The manufacturer and product family, in hexadecimal																										
Model ID	The model, in hexadecimal																										
Remod Chan	The interface to the subscriber TV; channel 3 or 4 in the USA																										
Set-top Time	The current OOB time displayed in global positioning system (GPS) seconds from Jan 6, 1980. It is an integer from 0 to 4294967295.																										

4 DIAGNOSTICS

Purchase Status

This diagnostic displays the status of subscriber event purchases on the OSD and front panel. The OSD and front panel displays are updated each time this diagnostic is viewed:

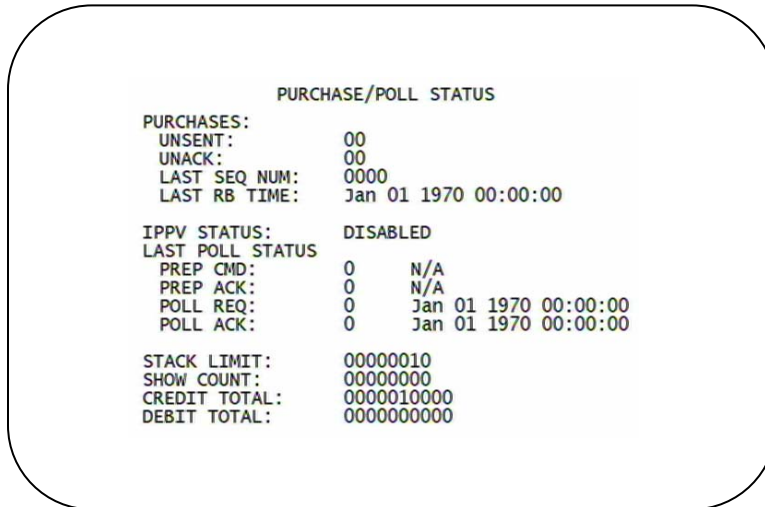
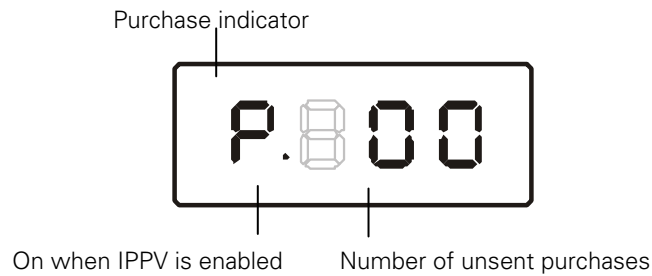

Figure 4-3 Front panel display for Purchase Status diagnostic



The Purchase Status fields are:

Field	Description
Unsent	The number of purchases in the DCH remaining to be polled. It can be an integer from 0 to 63.
Unack	The number of reports that have not been acknowledged by the controller. It is an integer.
Last Seq Num	The last acknowledged sequence number of a purchase sent by the controller. It is a 16-bit, unsigned hexadecimal number.
Last RB Time	The last time the DCH3416 attempted to report back purchases to the controller, in GPS seconds.
IPPV Status	If IPPV is enabled, the IPPV status indicator is on. If IPPV is disabled, the IPPV status indicator is off.
Prep CMD	“Last Prepare for Poll Command” sequence number and time of the last prepare for poll request command that was sent by the controller. Note that each requesting process maintains an independent sequence of poll requests to uniquely identify the poll responses.

4 DIAGNOSTICS

Field	Description
Prep ACK	"Last Prepare for Poll Acknowledge" sequence number and time of the last Report Purchase request sent by the controller.
Poll Request	Sequence number and time of the last send poll buffer command that was sent by the controller.
Poll Acknowledge	Sequence number and time of the last Poll Acknowledge message sent by the controller.
Stack Unit	Unit used in purchase processing
Show Count	Count used in purchase processing
Credit Total	Credit used for purchase processing
Debit Total	Debit used for purchase processing

Out-Of-Band (OOB) Status

This diagnostic indicates the out-of-band control channel status. The information is updated every 5 seconds.

OOB STATUS			
OOB FREQUENCY:	075.25 MHz		
CARRIER LOCK:	YES		
DATA:	YES		
EMM DATA:	YES		
SNR:	20.0 dB	GOOD	
AGC:	14 %	GOOD	
EMM PROVIDER ID:	0x0001		
EMM PID:	0x1503		
NETWORK PID:	0x0777		
HUNT MODE:	Hunted		
LKC:	075.25 MHz		

4 DIAGNOSTICS

Figure 4-4 Front panel display for the OOB diagnostic

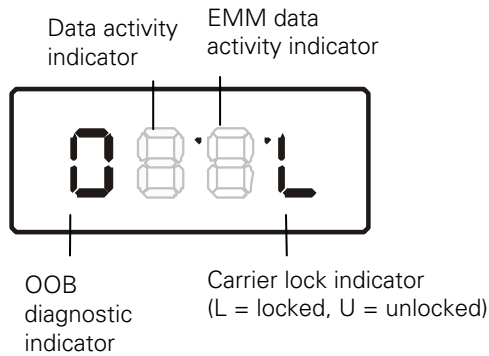

The Out-Of-Band Status fields are:

Field	Description		
OOB Frequency	Indicates the OOB tuner center frequency, from 70 to 130 MHz.		
Carrier Lock	Indicates whether the OOB receiver is locked to the carrier:		
	OSD	Front panel	Description
	YES	L	Carrier locked
	NO	U	Carrier unlocked
Data	Indicates whether data is being carried by the OOB and EMM traffic, which is tracked separately:		
	OSD	Front panel	Description
	YES	On	OOB data detected within the last 5 seconds
	NO	Off	OOB data not detected within the last 5 seconds
EMM Data	Indicates whether EMM data is being carried on the OOB stream:		
	OSD	Front panel	Description
	YES	On	EMM data detected within the last 5 seconds
	NO	Off	EMM data not detected within the last 5 seconds
SNR	When carrier lock has been established, displays an estimate of the carrier signal-to-noise ratio in dB, with an explanation: GOOD — Good value FAIR — Marginal signal level, check the signal POOR — Unusable signal INVALID — Invalid SNR value		
AGC	When carrier lock has been established, displays an estimate of the AGC as a percentage, with an explanation: GOOD — Good value FAIR — Marginal signal level, check the signal POOR — Unusable signal INVALID — Invalid AGC value		
EMM Provider ID	Displays the conditional access stream for the DCH3416, in hexadecimal		

4 DIAGNOSTICS

Field	Description
EMM PID	Displays the packet identifier (PID) stream the DCH3416 tunes to for EMM data, in hexadecimal
Network PID	Displays the network PID to which the DCH3416 is tuned to receive network messages, in hexadecimal
Hunt Mode	The hunt mode includes Hunted, None, Round Robin (RR), Search (SRCH), Fixed Frequency (FIX), or EMM Provider ID (EMM).
LKC	The last known carrier is the last valid OOB frequency displayed in MHz and ranges from 70 to 130 MHz, with the specific values of: 75.25, 104.20, 72.75, 92.25, 98.25, 107.25, 107.40, 110.25, 116.25, and 103.75. LKC will remain blank during hunting if a valid carrier has not been found, and will be populated once a valid OOB is found.

Agile OOB Tuner Hunting

An OOB frequency can be selected manually by pressing the MENU button while in the OOB Status diagnostics screen. To exit this mode, press the MENU button a second time, or press the POWER button.

If the set-top is in the process of hunting for an OOB frequency, control of frequency selection is suspended, i.e. pressing Menu button on OOB status screen to display MAN FREQ is not available when the set-top is hunting.

Summary of Manual Selection of the OOB Frequency (OSD Frequency Override in Hunted Mode)

The manual override frequency capability is only displayed if the box is not currently hunting and the operator presses the MENU key while OOB OSD diagnostics are displayed. The MAN Freq displays the LKC and allows the operator to select (via scroll up/down) a specific frequency to check if a valid OOB is on that specific frequency. The MAN Freq parameter is the OOB frequency selected in the frequency selection mode and displayed in MHz, with the specific values of 75.25, 104.20, 72.75, 92.25, 98.25, 107.25, 107.40, 110.25, 116.25, and 103.75.

1. When in the OOB Receiver Status Diagnostic, press the MENU button to enter the frequency selection mode. The frequency of the last known carrier is displayed on the Front Panel. The OSD displays a new "MAN FREQ" line at the bottom of the screen, which indicates the last known carrier frequency. At this point, if desired, the frequency change mode can be exited by pressing the MENU key a second time.
2. Use the UP/DOWN channel or cursor keys to scroll through all 10 frequencies until the desired new OOB frequency is found. The new frequency selections will appear on the Front Panel and on the "MAN FREQ" line of the OSD. When the last known frequency is selected, a DOT will appear in the middle-upper part of the Front Panel.
3. When the desired new frequency has been selected, press the SELECT key to start the search. The manual frequency search will last up to 40 seconds. As the set-top searches, the frequency being searched for will flash on the Front Panel. On the OSD, the "MAN FREQ" line of text will be cleared, the "HUNT MODE" will display "FIX" to indicate a search on a fixed frequency, and the "OOB FREQ" field will change to the frequency being searched for.

4 DIAGNOSTICS

4. If the frequency is found with the proper EMM Provider ID, then the Front Panel will display the normal OOB receiver status. The OSD "LKC" field will change to display the new frequency.
5. If after 40 seconds the frequency search is not successful, the product will perform a warm reset.
6. To abort a search without waiting the 40 seconds, the POWER key can be pressed to cause an immediate warm reset.

Note: The Front Panel will display "hunt" after a cold reset from the front panel. This indicates that the product is in a Round Robin Hunt Mode. "hunt" will continue to be displayed until the proper stream is detected.

In-Band Status

This diagnostic displays the in-band status for the last attempted tuned channel. The information is updated every 5 seconds.

IN-BAND STATUS	
IN-BAND TUNER 1	
MODE:	64 QAM
CARRIER LOCK:	YES
PCR LOCK:	YES
DATA:	YES
FREQUENCY:	0267.000 MHz
SNR:	26.4 dB FAIR
5 SECOND ERROR COUNTS:	
UNCORRECTABLE: 0000	CORRECTABLE: 0000
IN-BAND TUNER 2	
MODE:	N/A
CARRIER LOCK:	N/A
PCR LOCK:	N/A
DATA:	N/A
FREQUENCY:	N/A
SNR:	N/A N/A
5 SECOND ERROR COUNTS:	
UNCORRECTABLE: N/A	CORRECTABLE: N/A

4 DIAGNOSTICS

Figure 4-5 Front panel display for in-band diagnostic

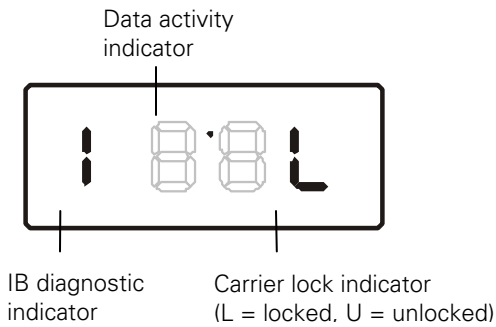

The In-Band Status fields are:

Field	Description		
Mode	The values displayed on the OSD are: 64 QAM — 64 QAM digital channel 256 QAM — 256 QAM digital channel		
Carrier Lock	Indicates whether the in-band receiver is locked to the carrier. If a digital carrier is not present, it indicates the carrier is not locked:		
	OSD	Front panel	Description
	YES	L	Carrier locked
	NO	U	Carrier not locked
PCR Lock	Indicates whether the in-band receiver is locked to the current program clock reference for a digital video service on the specified tuner. If a digital carrier is not present, it indicates the PCR is not locked.		
Data	Indicates whether data is being carried on the in-band stream. The indicators cover all packet processors regardless of the stream they are monitoring:		
	OSD	Front panel	Description
	YES	On	In-band data detected within the last 5 seconds
	NO	Off	In-band data not detected within the last 5 seconds
Frequency	The in-band frequency is center RF carrier frequency tuned for the digital service on the specified tuner. The frequency is displayed in MHz in xxxx.xxx format and ranges from 54 to 860 MHz.		
SNR	When carrier lock has been established, displays an estimate of the carrier signal-to-noise ratio in dB, with an explanation: GOOD — Good value FAIR — Marginal signal level, check the signal POOR — Unusable signal INVALID — Invalid SNR value		
5 Second Error Counts	Indicates the number of correctable and uncorrectable digital multiplex errors, up to 9999. It is updated every 5 seconds and reset each time the DCH3416 is power cycled or another digital multiplex is tuned. The maximum value displayed is 9999, even if there were more than 9999 errors.		

4 DIAGNOSTICS

Unit Address

This diagnostic displays the unit address of the CableCARD if inserted:

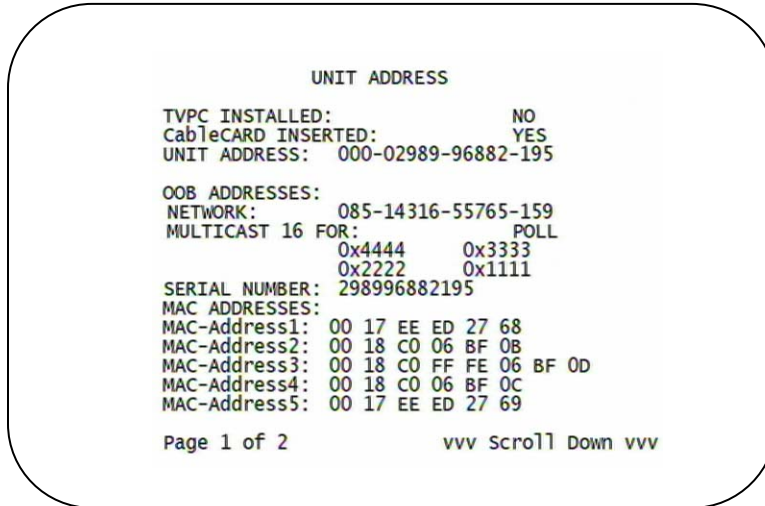
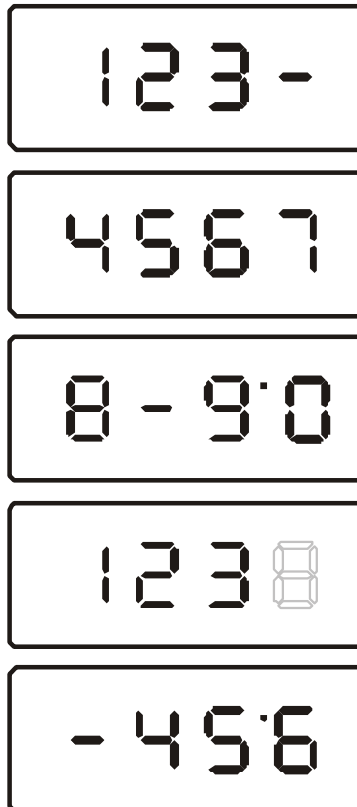

Figure 4-6 Front panel display of a unit address



4 DIAGNOSTICS

The Unit Address fields are:

Field	Description
TvPC Installed	Indicates whether the TvPC renewable security system is installed: NO — TvPC is not installed (Note: the DCH3416 does not include a TvPC slot)
CableCARD Inserted	YES — CableCARD is inserted NO — CableCARD is not inserted
Unit Address	A unique decimal number that indicates the unit address or physical address.
OOB Addresses	
Network	The DCH3416 network address displayed in decimal format.
Multicast 16 Address	Specifies the stream to which the OOB multicast 16 addresses are assigned. The stream type and multicast 16 addresses cycle on the OSD every 5 seconds. The valid stream types nnnn are: Net — Network EMM — EMM SCC — SCC_ECM Dnld — Download Data — Data Poll — Polling packet identifier (PID) The 16-bit multicast address is displayed in 4-byte hexadecimal format. The multicast 16 addressed messages filter on a 16-bit multicast address. The user processor can define up to four multicast addresses in hardware, and any message matching one of the four is processed. Messages not matching the multicast address are discarded.
Serial Number	The Host Serial Number is displayed on the Unit Address diagnostic screen.
MAC Addresses	The DOCSIS, Ethernet, 1394, USB, and MAC addresses are stored in protected flash and displayed in hexadecimal.

4 DIAGNOSTICS

Separable Security

This diagnostic displays information on the inserted M-CARD and CableCARD Interface with the DCH.

```

                                     *** Scroll Up ***
Separable Security
CARD Interface: GOOD
CableCARD ID: 000-299-006-404-6
Host ID: 044-000-025-204-7
Data ID: 298-740-142-43
Validation: UNKNOWN

Pairing Rpt Method: MMI
MSO Phone Number: 1-215-323-2000

CableCARD
Object Name: MCB1Card
Object Ver: 02.01
Manufacturer: 0x0000
HW Version: 0x0201

Page 2 of 2
  
```

Field	Description
CARD Interface	CableCARD Interface is a status indication of the interface between the Host and CableCARD. It will indicate "Good" if no errors are detected, "Error" if there is an error establishing the CableCARD interface, or "Unsupported CARD" if the inserted CableCARD is not an M-CARD.
CableCARD ID	The unique identifier provided by the CableCARD.
Host ID	The unique identifier in the Host Device Certificate.
Data ID	A value generated by the CableCARD for the Pairing report.
Validation	<ul style="list-style-type: none"> • UNKNOWN if a Validation message was not received by the product. • VALID or INVALID as set by the Host Validation Message received from the headend. • BINDING if the CableCARD is busy with the binding authentication process. • NOT BOUND if Card validation status is not bound for CableCARD reasons. • HOST CERTIFICATE INVALID if the status is not bound because the Host Certificate was invalid. • HOST SIGN FAILED if status is not bound because of failure to verify Host's SIGN. • AUTH KEY FAILED if status is not bound because of failure to match AuthKey from the Host Device. • FAILED if binding failed for other reasons.
Pairing Rpt Method	Set to "MMI" or "Reportback" as received by a message from the headend, or set to 'Unknown' if the headend message was not received.
MSO Phone Number	MSO Phone Number as configured at the headend.

4 DIAGNOSTICS

Field	Description
CableCARD	
Object Name	Code object name executing on the CableCARD.
Object Ver.	Code object version executing on the CableCARD.
Manufacturer	CableCARD manufacturer.
HW Version	Version number provided by the CableCARD.

Current Channel Status

This diagnostic displays a status of the last attempted channel you attempted to tune on the in-band stream. The channel type determines the status display.

```

CURRENT CHANNEL STATUS
PRIMARY A/V SOURCE:  TUNER 1
IB TUNER 1
TYPE: DIGITAL
STATUS:  Acquired and Locked  UNE
PREVIEW:  NO
PURCHASABLE:  NO
PURCHASED:  NO
EPOCH Num:  000
Auth Reason:  0x00
Service: 0      Status: 1      ID:0x020000
CH:  110      Tuned Frequency:  267.0000 MHz
VCT ID:  7
CCI:  0x00  APS:  0x00  RC Flag: 0x00
CIT:  0x00  DRM:  0x00  RS:  FOREVER

Page 1 of 2          vvv Scro1l Down vvv

```

```

CURRENT CHANNEL STATUS
IB TUNER 2
TYPE:
STATUS:  N/A
PREVIEW:  N/A
PURCHASABLE:  N/A
PURCHASED:  N/A
EPOCH Num:  N/A
Auth Reason:  N/A
Service: N/A      Status:  N/A      ID:N/A
CH:  N/A      Tuned Frequency:  N/A
VCT ID:  N/A
CCI:  N/A  APS:  N/A  RC Flag: N/A
CIT:  N/A  DRM:  N/A  RS:  N/A

Page 2 of 2

```

4 DIAGNOSTICS

Figure 4-7 Current channel status front panel displays

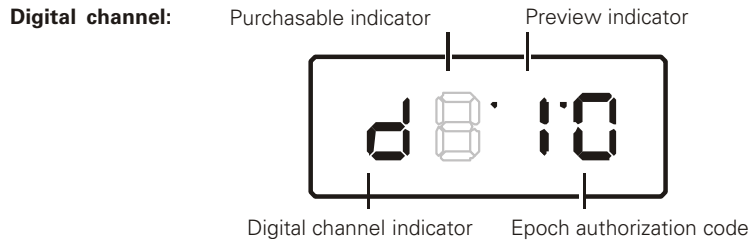

The Current Channel status fields are:

Field	Description		
Type	Indicates whether the channel is analog or digital:		
	OSD	Front panel	Description
	DIGITAL	d	Digital
aaa	Displays the encryption mode for the channel on the OSD and front panel. It is updated every 5 seconds. For a digital channel: ENC — encrypted UNE — unencrypted CLR — clear		
bb	(Digital channels only) The current epoch authorization reason is displayed in the hexadecimal format 0xbb on the OSD and front panel.		
In-Band Frequency	(Digital channels only) The center RF carrier frequency for the digital service. It can be from 54 to 860 MHz.		
Authorized	Indicates whether the DCH3416 is authorized for the currently tuned service: YES — authorized NO — not authorized		
Purchasable	Indicates whether the current program can be purchased for viewing:		
	OSD	Front panel	Description
	YES	on	Can be purchased
	NO	off	Cannot be purchased
Preview	Indicates whether the current program is in preview mode:		
	OSD	Front panel	Description
	YES	on	In preview mode
	NO	off	Not in preview mode
MPEG Video Lock	Indicates whether the video processor is locked to the video stream: YES — locked NO — not locked		
MPEG Audio Lock	Indicates whether the audio processor is locked to the audio stream: YES — locked NO — not locked		

4 DIAGNOSTICS

Field	Description
PCR Lock	Indicates whether the in-band receiver is locked to the program clock reference (PCR): YES — locked NO — not locked
CCI	The copy control information: 00 — copy free 01 — no more copies 10 — copy once 11 — never copy N/A — the value is invalid or cannot be retrieved
APS	The Analog Protection System; for example, Macrovision: 00 — No Macrovision 11 — Type 3 Macrovision N/A — the value is invalid or cannot be retrieved
RC Flag	Displays whether the broadcast flag is present: 0 — no flag/not defined 1 — the flag is present/enabled N/A — the value is invalid or cannot be retrieved
CIT	The constrained image trigger, as delivered in the PRK or the Set DRM API: 1 — set 0 — not set N/A — the value is invalid or cannot be retrieved
DRM	The digital rights management valid flag bit: 1 — set 0 — not set N/A—the value is invalid or cannot be retrieved
RS	The retention state: Forever, 1 week, 2 days, 1 day, 12 hours, 6 hours, 3 hours, 90 minutes, or Not Defined N/A — the value is invalid or cannot be retrieved

4 DIAGNOSTICS

RF Modem (Upstream)

This diagnostic displays the RF modem status, if an RF modem is installed in the DCH3416. The information is updated each time this diagnostic is displayed.

```
RF MODEM
STATUS:          CONFIGURED
CENTER FREQUENCY:    0008.096 MHz
REQUESTED POWER LEVEL:  045 dB
ACTUAL POWER LEVEL:   045 dB
REPORT BACK ADDRESS:  0x000000
```

4 DIAGNOSTICS

Figure 4-8 RF upstream modem front panel display

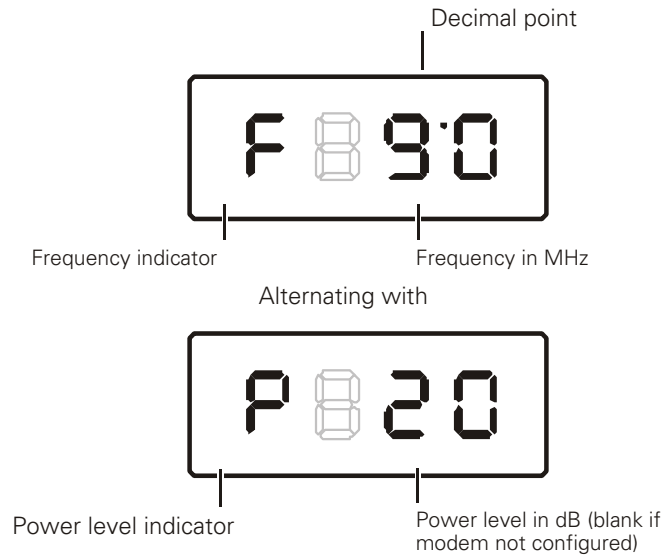

The RF Modem fields are:

Field	Description
Status	CONFIGURED or NOT CONFIGURED.
Center Frequency	The RF modem center frequency is displayed on the OSD and front panel in MHz.
Requested Power Level	The value in dB assigned to the DCH3416 during RF leveling (blank if it is not configured).
Actual Power Level	The power level is displayed in dB on the OSD and front panel or is blank if the power level has not been set.
Report Back Address	Displayed in 4-byte hexadecimal format, if configured.

4 DIAGNOSTICS

Code Modules

This diagnostic includes information about the firmware loaded in flash memory and all non-volatile code versions are installed on the DCH3416. When the native suite is running, the diagnostics of the application operating system and all associated objects should be accessible.

```
ASTB INVD
Boot Code: 06.06
Platform Built: Version: 1813t
Oct 25 2006 17:21:02
Digital Secure Processor: M01
Analog Secure Processor: N/A

Object Ver Status ID LO
EngCSD0t 18.13 ENABLED 0897 0
```

4 DIAGNOSTICS

Figure 4-9 Front panel display for code modules

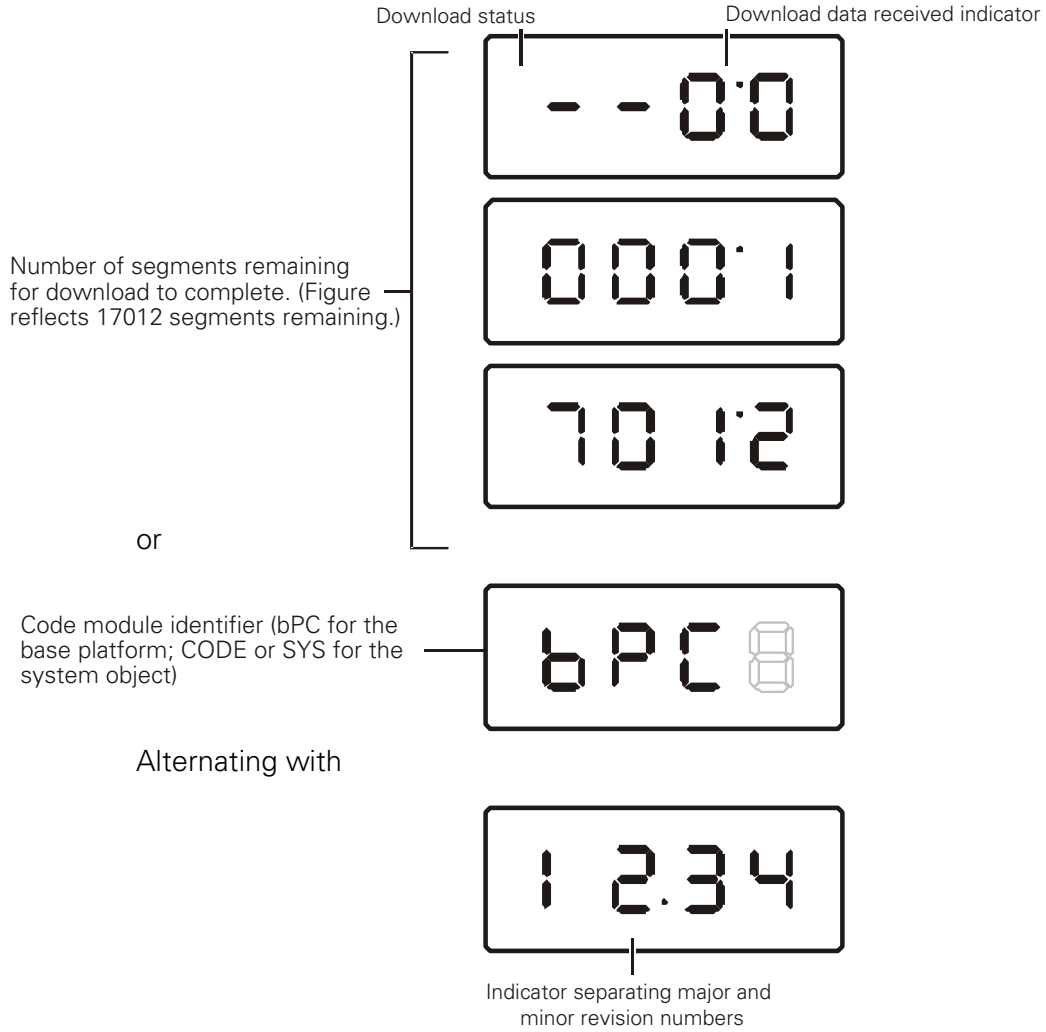

4 DIAGNOSTICS

The Code Modules fields are:

Field	Description		
Boot Code	The boot code version in ASCII format		
Version	The firmware version and build date in ASCII format		
Digital Secure Processor	The digital secure processor version in ASCII format		
Analog Secure Processor	The analog secure processor version in ASCII format		
Downloadable Object Information Table	Lists all objects loaded, or being loaded, onto the DCH3416 in ASCII format. The information displayed for each object depends on the running environment. If a download is not in progress, the front panel displays the currently running environment and version number, as shown in Figure 4-9. On the front panel, "bPC" represents Thin Client code.		
Object	The object name		
Ver	The object version		
Status	The object status, updated on the OSD and front panel every 5 seconds while you display the diagnostic:		
	OSD	Status	Description
	MEM ALLOC	Allocated	Memory for object is allocated
	LOADING	Loading	Object is being loaded
	STARTING	Enabling	Object is being started (the constructor is running)
	ENABLED	Enabled	Object is running
	ENA-NOT RUN	Enabled_Not_Runnable	Object is enabled, but cannot run
	STOPPING	Disabling	Object is being stopped (the destructor is running)
	DISABLED	Disabled	Object has been disabled
	DIS-NOT RUN	Disabled_Not_Runnable	Object is disabled and cannot run
	DELETING	Deleting	Object is being deleted
	POSTPONED	Postponed	Object cannot run on the current system; it will be enabled during the next boot
	CONNECTED	Connect	Connected to download PID — awaiting data
	PEND CONNECT	TryingToConnect	Trying to connect
ID	The object identifier		

4 DIAGNOSTICS

Memory Configuration

This diagnostic displays the DCH3416 memory configuration. The information is updated when you display the diagnostic.

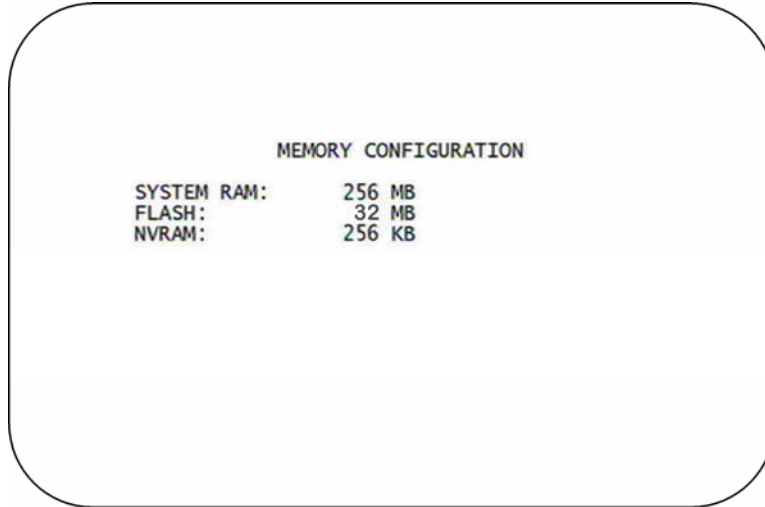

There is no front panel display for this diagnostic.

The Memory Configuration fields are:

Field	Description
System RAM	The allocated system RAM in MB.
Flash	The allocated flash memory in MB.
NVRAM	The allocated NVRAM in KB.

4 DIAGNOSTICS

Audio/Video Status

Audio/Video Status diagnostics display information regarding audio and video content and settings configured for the set-top.

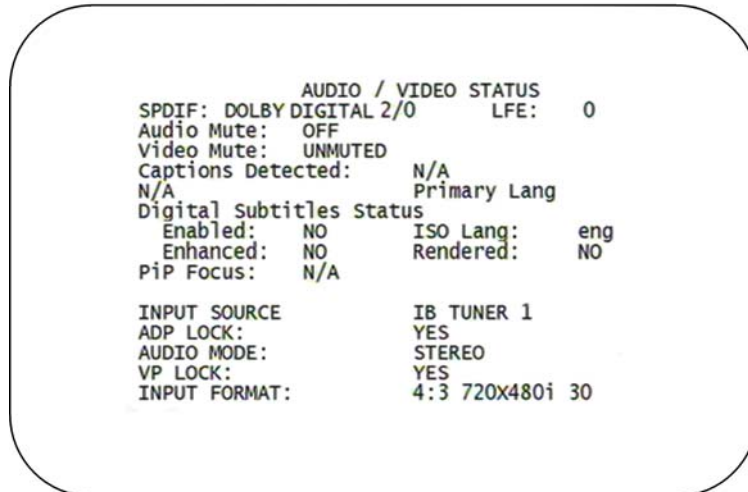

AUDIO SPDIF		Indicates SPDIF Mode as set by application software.
	OSD Display	Description
	N/A	Audio SPDIF mode is not applicable
	IEC958PCM	PCM audio selected
	Dolby Digital	For Dolby Digital selection, the following speaker selection is set:
	1/0	right front or left front
	2/0	right front and left front
	3/0	right front and left front and center
	2/1	right front and left front and (right rear or left rear)
	3/1	right front and left front and center and (right rear or left rear)
	2/2	right front and left front and right rear and left rear
	3/2	right front and left front and center and right rear and left rear
	LFE: Low Frequency Effect	The LFE indicates if the nomenclature low frequency effects are available in the Dolby Digital audio stream as indicated if the "0.1" is present in the Dolby Digital 5.1 nomenclature (for example, "Dolby Digital 5.1 surround"). Valid values include:
	OSD Display	Description
	0	LFE is not available
	1	LFE is available (for example, "Dolby Digital 5.1 surround").
	Muting State and Method	The Audio and Video Mute Status indicates if the audio and/or video has been muted by the software. The audio mute is either "On" or "Off." The Video Mute describes the MPEG muting method selected by the software and indicates if the output video is in the mute state by displaying "On" or "Off," followed by the mute method. Methods include:

4 DIAGNOSTICS

	OSD Display	Description
	UNMUTED	Displayed if mute method is not selected
	MUTE to STILL	Displayed if the mute method includes stopping video and presenting a still frame, similar to a pause function
	MUTE to BLACK	Displayed if mute method presents a black screen.
Captions		The captions mode displays captions present on the service. Note: The caption options are set via the User Setting Menu, where the subscriber can enable closed captions and select options.
1st Caption Row: Caption Detected:		
	OSD Display	Description
	708	EIA-708 captions detected
	608	EIA-608 captions detected
	608 and 708	Both EIA-608 and EIA-708 captions detected
	None	No Captions detected
2nd Caption Row: Caption Options Set, followed by Service Selected (xxxxxxxxxxxx):		
	OSD Display	Description
	708 Set xxxxxxxxxxxx	EIA-708 captions enabled, with options set by user
	708 Default xxxxxxxxxxxx	EIA-708 captions enabled, with no options set by user
	608 Set xxxxxxxxxxxx	EIA-608 captions enabled, with options set by user
	608 Default xxxxxxxxxxxx	EIA-608 captions enabled, with no options set by user
	None Set	Captions detected but not enabled

The OSD status, 2nd caption row displays captions based on the setting selected in the User Settings menu and what is available in the stream.

708 or 608 is the type of caption displayed, dependent on what was detected.

The Set or Default directly reflects the User Setting Status parameter of "SETTINGS," which is "Auto" for Default or "User" for set by user via the User Setting Menu.

The xxxxxxx parameter should directly reflect the User Setting Status parameter of "SERVICE SELECTION" for Analog or Digital services as described below.

xxxxxxxxxxxx is the Service Selected parameter (which should directly reflect the User Setting Status parameter of "SERVICE SELECTION" for Analog or Digital services) and will be shown as one of the following if captions are enabled (See section 16.5 and 16.6 for further information on service selection):

	xxxxxxxxxxxx OSD Display	Definition
	CC 1	Closed Caption service CC 1 (default)
	CC 2	Closed Caption service CC 2
	CC 3	Closed Caption service CC 3
	CC 4	Closed Caption service CC 4

4 DIAGNOSTICS

	T 1	Closed Caption service T 1
	T 2	Closed Caption service T 2
	T 3	Closed Caption service T 3
	T 4	Closed Caption service T 4
	Primary Lang	Primary language established by the provider (default, Service 1)
	Second Lang	Secondary language established by the provider (Service 2)
	Service 3	Set by the provider Service 3.
	Service 4	Set by the provider Service 4.
	Service 5	Set by the provider Service 5.
	Service 6	Set by the provider Service 6.
Digital Subtitle Status	<p>The subtitle parameter indicates if subtitles are enabled and, if enabled, what language is selected and if the subtitle is being rendered. The language is displayed as the 3-character ISO639.2/B language code.</p> <ul style="list-style-type: none"> • Enabled is indicated with Yes or No. • The language is displayed as the 3-character ISO639.2 language code. • Enhanced mode is indicated with Yes or No. • Rendered status is indicated with Yes or No. 	
PIP Focus	<p>The Picture in Picture focus indicates N/A and is not a standard supported DCH feature (dependent upon application software).</p>	
Input Sources	<p>The input source list information on ADP Lock, Audio Mode, VP lock, and Input Format.</p> <p>The ADP Lock indicates whether the audio stream is locked. Valid values are:</p> <ul style="list-style-type: none"> • YES: Audio Processor is locked to the audio stream • NO: Audio Processor is not locked to the audio stream <p>Audio Mode indicates the audio Mode of in incoming digital service. Valid values include:</p> <ul style="list-style-type: none"> • N/A: the audio mode is not applicable to the currently tuned stream • Mono: the audio mode is monophonic • Stereo: the audio mode is stereo • Surround: the audio mode is surround sound • 5.1: the audio mode is Dolby Digital 5.1 surround sound <p>VP Lock indicates whether the video stream is locked. Valid values are:</p> <ul style="list-style-type: none"> • YES: Video Processor is locked to the video stream • NO: Video Processor is not locked to the video stream <p>The input format includes the aspect ratio (4:3 or 16:9), the screen pixel size (nnnXnnn), pixel display ('i' for interlaced, 'p' for progressive), and frames per second (24, 25, 30, or 60).</p>	

4 DIAGNOSTICS

Interface Status

The Interface Status diagnostic displays when running in Thin Client. There is no LED display. The information on the OSD is updated when you display the diagnostic.

INTERFACE / PORT STATUS		
	ENABLED	ACTIVE
DOCSIS	YES	NO
1394	YES	NO
DVI/HDMI	NO	NO
ETHERNET	YES	NO
IR XMIT	YES	YES
SMART CARD	NO	NO
SPDIF	YES	YES
RF BYPASS	NO	NO
USB	YES	NO
HMA AUTHORIZED	NO	NO
MOCA AUTHORIZED	NO	NO
Internal	YES	NO
External	YES	YES

Page 1 of 4 vvv Scro]] Down vvv

INTERFACE / PORT STATUS		
DVI/HDMI		
MODE:	N/A	COLOR SPACE: RGB
DEVICE CONNECTED:	NO	
REPEATER:	N/A	
VIDEO XMISSION:	N/A	
HDCP ENABLED:	N/A	
OUTPUT FORMAT:	N/A	
ASPECT RATIO:	N/A	
EDID DATA	N/A	
NO DATA AVAILABLE		

AUDIO: PCM RATE: 32KHz

Page 2 of 4 vvv Scro]] Down vvv

4 DIAGNOSTICS

```
          ^^^ Scroll Up ^^^  
          INTERFACE / PORT STATUS  
1394  
ACTIVE PORTS:          0  
DATA XMISSION:        NOT ACTIVE  
5C IMPLEMENTATION:    NO  
COPY CONTROL:         Copy Free  
CYCLE MASTER NODE:    YES  
IRM NODE:             YES  
ROOT NODE:            YES  
LOOP DETECTED :      NO  
  
EUI-64:                0x0018C0FFFE06BF0D  
  
CONNECTED DEVICES: 01  
  DEVICE ID  
  0x0018C0FFFE06BF0D  
  N/A  
  N/A  
Page 3 of 4          vvv Scroll Down vvv
```

```
          ^^^ Scroll Up ^^^  
          INTERFACE / PORT STATUS  
  
USB DEVICES  
NO DEVICES
```

Page 4 of 4

4 DIAGNOSTICS

The Interface Status fields are:

Field	Description
DOCSIS Tuner & Xmitter	Indicates if enabled; indicates if active
1394 I/O Device	Indicates if enabled; indicates if active
USB I/O Device	Indicates if enabled; indicates if active
Ethernet Device	Indicates if enabled; indicates if active
Parallel Port	Indicates if enabled; indicates if active
IR Xmit	Indicates if enabled; indicates if active
Hard Drive Status	Indicates if enabled; indicates if active
Smart Card	Indicates if enabled; indicates if active
HDMI Port	<p>If a device is connected to the HDMI port only, the following diagnostics display to help troubleshoot the HDMI interface. They all display "N/A" if no device is connected to the HDMI port, or the value is invalid or cannot be retrieved.</p> <ul style="list-style-type: none"> • Device Connected — Indicates whether a device is connected to the HDMI port—Yes or No. • Repeater — Indicates whether the connected device is a repeater — Yes or No. • Video Xmission (transmission) — Indicates whether the DCH3416 is transmitting video over the HDMI port — Not Active or Active. • HDCP Enabled — Indicates whether the DCH3416 is using HDCP to encrypt video transmitted over the HDMI link — Yes or No. If the Video Xmission status is Not Active, the HDCP Enabled status is No. • Output Format — Indicates the timing format of the video sent through HDMI: <ul style="list-style-type: none"> 1920 x 1080I — 1920 pixels wide by 1080 pixels high, interlaced 1280 x 720P — 1280 pixels wide by 720 pixels high, progressive 720 x 480P — 720 pixels wide by 480 pixels high, progressive 720 x 480I — 720 pixels wide by 480 pixels high, interlaced 640 x 480P — 640 pixels wide by 480 pixels high, progressive • Aspect Ratio — Indicates the aspect ratio of the video sent through HDMI — 4:3 or 16:9.
EDID Data	<p>Indicates the video timing formats that were read from the Extended Display Identification Data (EDID) register for the connected device, in particular the detailed timing description blocks. The list displays all of the formats that the DCH3416 could read, up to a maximum of 12 formats. If the DCH3416 cannot read any formats, EDID Data is blank. An asterisk (*) after the aspect ratio means the DCH3416 supports the format. If more than twelve video timing formats are discovered, the supported formats only are listed first, followed by up to twelve remaining formats.</p>

4 DIAGNOSTICS

User Setting Status

This diagnostic displays the user settings. The format may vary. The information on the OSD and front panel is updated when you display the diagnostic.

USER SETTING STATUS	
TV TYPE:	16:9
YPbPr OUTPUT	1080i
4:3 OVERRIDE	480i
CLOSED CAPTION	DISABLED
SERVICE SELECTION	
ANALOG	CC1
DIGITAL	PRIMARY LANG
FONT SIZE	AUTO
FONT STYLE	AUTO
FONT COLOR	AUTO
FONT OPACITY	AUTO
FONT EDGE TYPE	AUTO
FONT EDGE COLOR	AUTO
BACKGROUND COLOR	AUTO
BACKGROUND OPACITY	AUTO
SETTINGS	AUTO

The User Setting Status fields are:

Setting	Description
TV Type	<p>Allows you to specify the style of television connected to the DCH receiver. Options include 16:9, 4:3 LETTERBOX, and 4:3 PAN SCAN. The 16:9 option is the default selection. The options are used as follows:</p> <ul style="list-style-type: none"> • 16:9 designates that a widescreen television is connected to the DCH receiver. • 4:3 LETTERBOX designates that a standard-screen television is connected to the DCH receiver and that widescreen programs should be scaled to fit the screen with black bars above and below the picture. • 4:3 PAN SCAN designates that a standard-screen television is connected to the DCH receiver and that widescreen programs should be cropped so that the picture fills the entire screen.
HDMI/YPbPr Output	<p>Allows you to specify the video output format of the DCH receiver for all content (when the 4:3 override setting is Off) or for all 480p, 720p, and 1080i content (when the 4:3 override is used). Options include 1080i, 720p, 480p, and 480i. By default, the 1080i option is selected. The options are used as follows:</p> <ul style="list-style-type: none"> • 1080i — The DCH receiver will present programs in the High-Definition 1080i format (1920 x 1080 pixels). • 720p — The DCH receiver will present programs in the High-Definition 720p format (1280 x 720 pixels). • 480p — The DCH receiver will present programs in the Enhanced-Definition 480p format (720 x 480 pixels). • 480i — The DCH receiver will present programs in the Standard-Definition 480i format (720 x 480 pixels). <p>Some televisions may only support certain video formats. Please consult your television's user manual for more information on format compatibility.</p> <p>The DCH receiver can detect when the HDMI connection is in use. If you are not using the HDMI connection on the DCH receiver, the HDMI/YPbPr Output setting will</p>

4 DIAGNOSTICS

Setting	Description
	display as YPbPr Output in the User Settings Menu.
4:3 Override	<p>The 4:3 Override setting allows you to specify the video output format of the DCH receiver when it is tuned to a Standard-Definition program or playing back a Standard-Definition program from the DVR. Options include 480i, 480p, Stretch, and Off. By default, the 480i option is selected. The options are used as follows:</p> <ul style="list-style-type: none"> • 480i — The DCH receiver will present Standard-Definition programs in the Standard-Definition 480i format (720 x 480 pixels). • 480p — The DCH receiver will present Standard-Definition programs in the Enhanced-Definition 480p format (720 x 480 pixels). • Stretch — The DCH receiver will automatically stretch all Standard-Definition programs to a widescreen aspect ratio and present the video in the format designated by the HDMI/YPbPr Output setting. Note that the Stretch option is only available when the TV Type setting is 16:9. • Off — The DCH will create a widescreen version of a Standard-Definition program by adding black bars to the left and the right of the picture and present the video in the format designated by the HDMI/YPbPr Output setting. <p>Some televisions may only support certain video formats. Please consult your television's user manual for more information on format compatibility.</p> <p>If the HDMI/YPbPr Output setting is 480i, the 4:3 Override feature is disabled and is no longer selectable in the menu. The 4:3 Override feature is available when the HDMI/YPbPr Output setting is 1080i, 720p, or 480p.</p>
Closed Caption	Turns closed captions off or on. The front panel display indicates the status of the closed captions. Defaults to DISABLED. Options are ENABLED or DISABLED.
Service Selection	<p>Sets the service used for closed captions:</p> <ul style="list-style-type: none"> • Digital: PRIMARY LANGUAGE, SECONDARY LANGUAGE, 3, 4, 5, or 6. The default is PRIMARY LANGUAGE.
Font Size	Sets the font size for closed captions. Defaults to AUTO. Options are AUTO, STANDARD, LARGE, or SMALL.
Font Style	Sets the font style for closed captions. Defaults to AUTO. Options are AUTO, MONO SERIF, PROPORTION SERIF, MONO NO SERIF, PROPORTION NO SERIF, CASUAL, CURSIVE, or SMALL.
Font Color	Sets the font color. Defaults to AUTO. Options are AUTO, WHITE, BLACK, RED, GREEN, BLUE, YELLOW, MAGENTA, or CYAN.
Font Opacity	Sets the opacity. Defaults to AUTO. Options are AUTO, TRANSPARENT, TRANSLUCENT, SOLID, or FLASHING.
Font Edge Type	Sets the edge appearance — AUTO, NONE, RAISED, DEPRESSED, UNIFORM, LEFT SHADOWED, or RIGHT SHADOWED. The default is AUTO.
Font Edge Color	Sets the edge color — AUTO, WHITE, BLACK, RED, GREEN, BLUE, YELLOW, MAGENTA, or CYAN. The default is AUTO.
Background Color	Sets the background color for closed captions. Defaults to AUTO. Options are AUTO, WHITE, BLACK, RED, GREEN, BLUE, YELLOW, MAGENTA, or CYAN.
Background Opacity	Sets the background opacity for closed captions. Defaults to AUTO. Options are AUTO, TRANSPARENT, TRANSLUCENT, SOLID, or FLASHING.
Settings	Sets the default settings for closed captions (AUTO) or the settings you have configured (USER). Defaults to AUTO. Options are AUTO or USER.
Restore All Defaults	To reset all User Settings to their defaults, select this option and press the ► key.

4 DIAGNOSTICS

DVR/Hard Drive Status

This two-page diagnostic displays the DVR and hard-drive status.

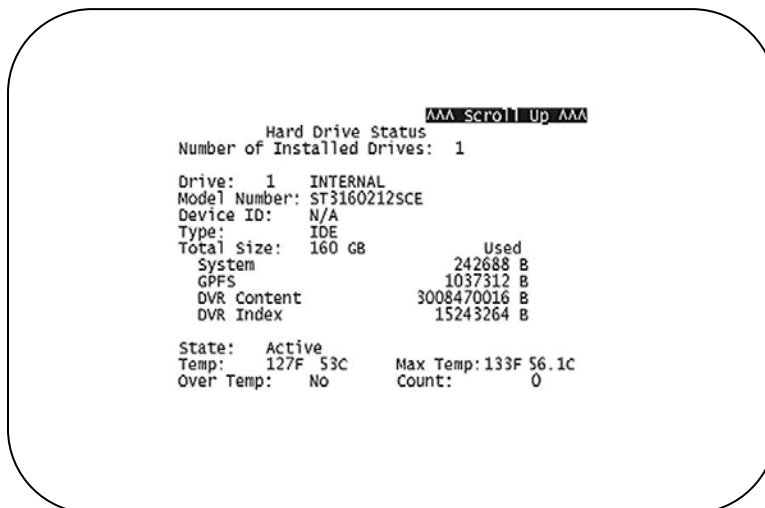
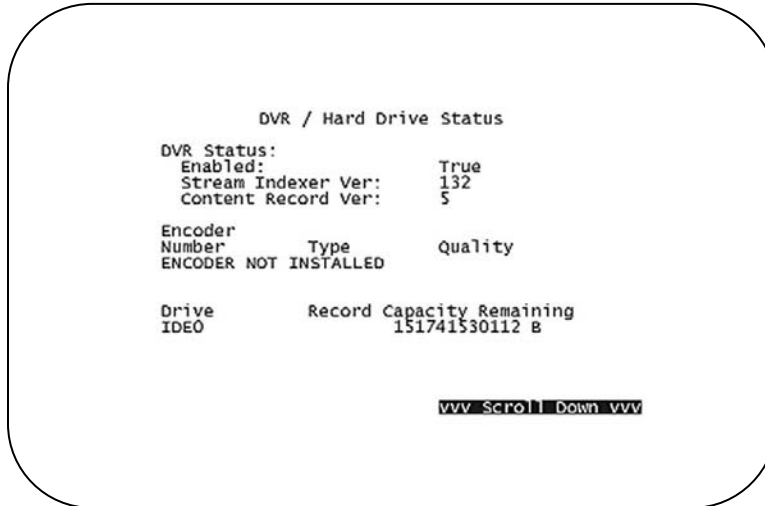

The DVR/Hard Drive Status fields are:

Field	Description		
Enabled	Indicates whether the DVR is enabled, based on the DCH3416 Connected State (CONNECTED or DISCONNECTED) and resource availability (resource authorized; hard disk installed and functional):		
	OSD	Front panel	Description
	True	En	DVR enabled
	False	Un	DVR disabled
Stream Indexer Ver.	The stream indexer version number, without leading zeros; for example, version 0000000065 is displayed as "65"		

4 DIAGNOSTICS

Field	Description
Content Record Ver.	The content record version number, displayed without leading zeros
Encoder	Information about the analog encoder for the IEEE-1394 output and recording analog programs
Number	Indicates the encoder number — 1 or 2
Type	Indicates the encoder type — Not Installed, MPEG2, Other, or Unknown
Quality	Indicates the encoder quality setting (video bit rate) for analog services only, which may change at any time through software: <ul style="list-style-type: none"> • LOW1 — 1 Mbps • LOW2 — 2 Mbps • MEDIUM1 — 3 Mbps • MEDIUM2 — 4 Mbps • HIGH1 — 5 Mbps • HIGH2 — 6 Mbps • NOT AVAILABLE — the encoder is not enabled or configured
Drive	The drive type — IDE (internal), 1394, USB (external), or NOT AVAILABLE (neither enabled nor configured)
Record Capacity Remaining	The remaining recording capacity, in bytes
Number of Installed Drives	The number of internal and external hard drives, up to a maximum of 9
Drive	The identification number sequentially assigned to each installed drive and whether the drive is Internal or External
Model Number	The drive model number assigned at the factory
Device ID	A text string of up to 20 characters that identifies the disk drive; "N/A" is displayed if the value is invalid or cannot be retrieved
Type	The drive type — IDE, 1394, USB, or Unkn(own)
Total Size	The drive size in decimal GB. (1 decimal GB = 1x109 bytes. For example, 120 decimal GB = 120x109 bytes.)
System, GPFS, DVR Content, and DVR Index	The space used and allocated in MB for each of the internal hard drive's partitions — System, GPFS, DVR Content, and DVR Index (1 binary MB = 220 bytes). "N/A" displays if the value is invalid or cannot be retrieved.
State	The hard drive state: <ul style="list-style-type: none"> • Standby — The hard drive is working normally, but is at rest (the State returns to Active any time disc access is necessary). • Active — The hard drive is accessing data. • Failed — The hard drive hardware has failed.
Temp (F)	For an internal hard drive only, its temperature in degrees F

4 DIAGNOSTICS

Field	Description
Max Temp	For an internal hard drive only, its maximum temperature in degrees F
Over Temp	Indicates whether the drive is excessively hot: <ul style="list-style-type: none"> • Yes — The internal drive temperature exceeds 140° F (60° C). The LED Over-Temp Indicator is on and remains lit until the next over-temp sample is taken (at least once an hour). • No — There is no over temp problem.
Count	The cumulative number of times that the hard drive temperature has been measured over 60° C, with the temperature checked at least once an hour.

DOCSIS Status

This three-screen diagnostic displays status information for the embedded cable modem (eCM):

```

DOCSIS STATUS
DOCSIS Enabled:                NO
Acquire DS Channel:            N/A
Obtain US Parameters:          N/A
Establish IP Connectivity:      N/A
Obtain Configuration File:     N/A
eCM Registered:                N/A
Network Access:                N/A
Initialize BPI:                N/A
System UP Time:
    000 Days 00 Hours
    00 Mins 00 Seconds

IP Addresses
Cable Modem:                   000.000.000.000
Set-top Box:                   000.000.000.000

Page 1 of 3  vvv Scroll Down vvv

```

```

DOCSIS
MAC addresses
Cable Modem:                   00:00:00:00:00:00
Set-top Box:                   00:00:00:00:00:00
Downstream Channel
Carrier Lock:                   N/A
Frequency:                      N/A
LKC:                            N/A
Mode:                            N/A
Power Level:                    000 dBmV
SNR:                            00.0 dB
Upstream Channel
Frequency:                      N/A
Mode:                            N/A
Channel ID:                     N/A
Power Level:                    000 dBmV
Symbol Rate:                    0.000 MSym/sec

Page 2 of 3  vvv Scroll Down vvv

```

4 DIAGNOSTICS

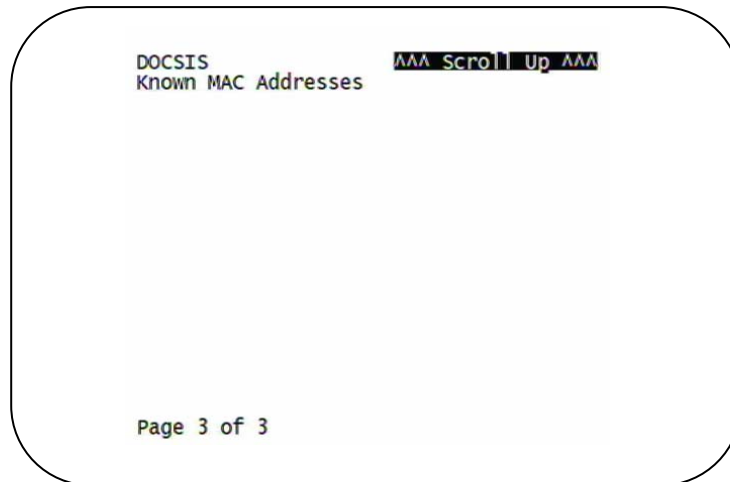

The fields are:

Field	Description
DOCSIS Enabled	For a DOCSIS-enabled set-top, YES. Otherwise, NO.
Acquire DS Channel	The DOCSIS downstream channel acquisition status: <ul style="list-style-type: none"> • YES — The downstream channel is acquired • NO — The set-top is acquiring the downstream channel • N/A — The value is invalid or cannot be retrieved, or DOCSIS is not enabled
Obtain US Parameters	The DOCSIS upstream channel descriptor (UCD) acquisition status: <ul style="list-style-type: none"> • YES — The UCD is acquired • NO — The set-top is acquiring the UCD or the downstream channel • N/A — The value is invalid or cannot be retrieved, or DOCSIS is not enabled
Establish IP Connectivity	Displays whether the cable modem has acquired its IP address, typically from a Dynamic Host Configuration Protocol (DHCP) server: <ul style="list-style-type: none"> • YES — The IP address is acquired • NO — The set-top is acquiring its IP address • N/A — The value is invalid or cannot be retrieved, or DOCSIS is not enabled
Obtain Configuration File	Displays whether the cable modem has downloaded its DOCSIS cable modem configuration file from the TFTP server: <ul style="list-style-type: none"> • YES — The cable modem configuration file has been successfully downloaded • NO — The set-top is downloading its cable modem configuration file • N/A — The value is invalid or cannot be retrieved, or DOCSIS is not enabled
eCM Registered	Displays whether the embedded cable modem has registered with the cable modem termination system (CMTS): <ul style="list-style-type: none"> • YES — DOCSIS registration is complete • NO — DOCSIS registration is in progress, or the set-top could not register • N/A — The value is invalid or cannot be retrieved, or DOCSIS is not enabled

4 DIAGNOSTICS

Field	Description
Network Access	Displays whether the cable modem has been granted access to the DOCSIS network: <ul style="list-style-type: none"> • YES — The cable modem was granted DOCSIS network access • NO — The set-top is obtaining DOCSIS network access • N/A — The value is invalid or cannot be retrieved, or DOCSIS is not enabled
Initialize BPI	The Baseline Privacy Interface (BPI) status: <ul style="list-style-type: none"> • YES — BPI has been successfully initialized for the cable modem • NO — BPI initialization is in progress, has failed, or was not requested by the network • N/A — The value is invalid or cannot be retrieved, or DOCSIS is not enabled
System Up Time	The Days , Hours , Mins (minutes), and Seconds the DOCSIS system has been operational. If the value is invalid or cannot be retrieved, or if DOCSIS is not enabled, each field displays zeros.
IP Addresses	The Cable Modem and Set-Top IP addresses in dotted-decimal format xxx.xxx.xxx.xxx. Each byte value is padded with zeros when necessary. For example, 10.0.1.10 is displayed as 010.000.001.010. If the value is invalid or cannot be retrieved, or if DOCSIS is not enabled, 000.000.000.000 is displayed.
MAC Addresses	The Cable Modem and Set-Top MAC address in hexadecimal format xx:xx:xx:xx:xx:xx. Each byte value xx ranges from 00 to FF and is padded with zeros when necessary. For example, 0:0:2D:1:F1:D is displayed as 00:00:2D:01:F1:0D. If the value is invalid or cannot be retrieved, or if DOCSIS is not enabled, 00:00:00:00:00:00 is displayed.
Downstream Channel (carries data from the headend to the set-top)	
Carrier Lock	<ul style="list-style-type: none"> • YES — The cable modem is locked to a DOCSIS downstream channel • NO — The cable modem is not locked to a downstream channel • N/A — The value is invalid or cannot be retrieved, or DOCSIS is not enabled
Frequency	The center frequency of the channel to which the DOCSIS downstream channel receiver is tuned. It can be 54 to 860 MHz. If the value is invalid or cannot be retrieved, downstream Carrier Lock is NO, or if DOCSIS is not enabled, N/A is displayed.
LKC	The last known carrier (LKC); the frequency of the last tuned downstream channel used if the embedded cable modem enters hunt mode. It can be 54 to 860 MHz. If the value is invalid or cannot be retrieved, Carrier Lock is NO, or if DOCSIS is not enabled, N/A is displayed.
Mode	The DOCSIS downstream channel modulation: QAM 64 or QAM 256. If the value is invalid or cannot be retrieved, Carrier Lock is NO, or if DOCSIS is not enabled, 000 is displayed.
Power Level	The downstream channel power level in dBmV. If the value is invalid or cannot be retrieved, Carrier Lock is NO, or if DOCSIS is not enabled, 000 is displayed.
SNR	The estimated downstream channel carrier signal-to-noise ratio in the format xx.x dB. It is the value reported as SNR in the MIB. If the value is invalid or cannot be retrieved, Carrier Lock is NO, or if DOCSIS is not enabled, 00.0 is displayed.
Upstream Channel (carries data from the set-top to the headend)	
Frequency	The center frequency of the channel to which the DOCSIS upstream channel receiver is tuned. It can be 5 to 42 MHz. If the value is invalid or cannot be retrieved, Carrier Lock is NO, or if DOCSIS is not enabled, N/A is displayed.

4 DIAGNOSTICS

Field	Description
Mode	The DOCSIS upstream channel modulation: QPSK, QAM 8, QAM 16, QAM 32, QAM 64, or QAM 128. If the value is invalid or cannot be retrieved, or if DOCSIS is not enabled, N/A is displayed.
Channel ID	The upstream channel identifier 0 to 255. If the value is invalid or cannot be retrieved or DOCSIS is not enabled, N/A is displayed.
Power Level	The upstream channel power level in dBmV. If the value is invalid or cannot be retrieved, or if DOCSIS is not enabled, 000 is displayed.
Symbol Rate	The upstream channel symbol rate in mega-symbols per second. If the value is invalid or cannot be retrieved, or if DOCSIS is not enabled, 0.000 is displayed.
Known MAC Addresses	Displays up to 32 MAC addresses learned by the DCH3416 cable modem, including the Set-Top MAC and future MAC addresses assigned by DSG, in hexadecimal format xx:xx:xx:xx:xx:xx on two screens if necessary. If the value is invalid or cannot be retrieved, or if DOCSIS is not enabled, no values are displayed.

Application Specific Information

This diagnostic displays information about application servers:

```

APPLICATION SPECIFIC INFORMATION
NO ADDITIONAL INFORMATION

SERVER 1 NAME:
SRV 1 IP ADDR:

SERVER 2 NAME:
SRV 2 IP ADDR:

SERVER 3 NAME:
SRV 3 IP ADDR:

SERVER 4 NAME:
SRV 4 IP ADDR:

SERVER 5 NAME:
SRV 5 IP ADDR:

```

The fields are:

Field	Description
Server# Name	The application server name of up to 14 alphanumeric characters. It is blank if the value is invalid or no value can be retrieved.
Srvr # IP Addr	The application server's IP address in dotted-decimal format xxx.xxx.xxx.xxx; each xxx is from 0 to 255. It is blank if the value is invalid or no value can be retrieved.

4 DIAGNOSTICS

Interactive Status

This diagnostic describes the interactive information that is displayed only when the Thin Client platform is running. The information on the OSD and front panel is updated at least once every 5 seconds while the diagnostic is displayed. This is an example of a code module display with status descriptions:

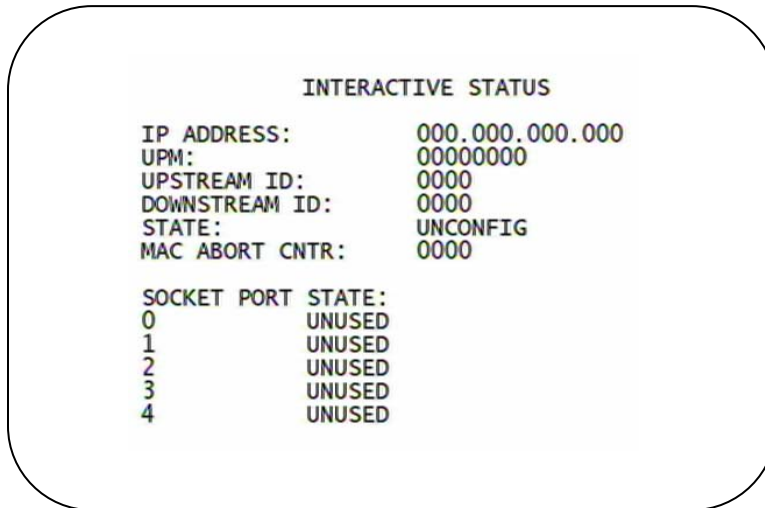
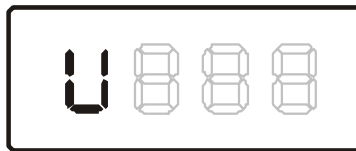

Figure 4-10 Interactive status front panel display



The Interactive Status fields are:

Field	Description		
IP Address	The IP address in dotted-decimal format xxx.xxx.xxx.xxx assigned by the NC 1500 to the DCH3416. 0.0.0.0 is displayed if the IP address is not configured or unknown.		
UPM	The upstream modem address value is the same as the terminal ID assigned by the DAC 6000. It is a unique, system-generated, eight-digit integer between 1 and 16777215. 00000000 is displayed when the UPM is not configured or if it is unknown.		
Upstream ID	A four-digit decimal value from 0000 to 9999 assigned by the DAC 6000 to the DCH3416. 0000 is displayed if the Upstream ID is not configured or if it is unknown.		
Downstream ID	A four-digit decimal value from 0000 to 9999 assigned by the DAC 6000 to the DCH3416. 0000 is displayed if the Downstream ID is not configured or if it is unknown.		
State	The interactive status of the DCH3416:		
	Front Panel	OSD	Description
	U	UNCONFIG	The DCH3416 is not configured for the interactive system, and the platform should run as pre-interactive.
	C	MAC_CONNECT	The DCH3416 is waiting to establish a connection to the MAC PID Stream.

4 DIAGNOSTICS

Field	Description		
	l dc	INIT_WAIT_DC_OR_C	The DCH3416 is in the interactive initialization state and waiting for the default configuration or the contention channel list messages.
	l L	WAIT_LM_ACK	The DCH3416 is in the interactive initialization state and waiting for Link Management Response ACK for Local Address Message.
	l SO	WAIT_SO_ACK	The DCH3416 is in the interactive initialization state and waiting for a Sign On acknowledgement.
	l LA	WAIT_LA_OR_S O	The DCH3416 is in the interactive initialization state and waiting for Logical Address or Sign On with verification Frequency message.
	S I	INIT_STOPPED	The DCH3416 is in the interactive initialization state and the TransMode has stopped.
	r dc	RUN_WAIT_DC_OR_C	The DCH3416 is in the interactive state and waiting for the default configuration or the contention channel list messages.
	r	RUNNING	Interactive state is running, sending idle messages, and waiting for any prepare for poll or MAC messages.
	S	RUN_STOPPED	The interactive run state has stopped and DCH3416 is waiting for status or a transmission control message.
	00	INVALID	The interactive state is unknown or invalid.
MAC Abort Cntr	This counter increments every time the MAC layer reaches the cell abort count limit. It is reset by the successful upstream transmission of a cell: for example, when the DCH3416 receives an ACK. If the counter reaches the MAC abort count limit, the DCH3416 assumes the MAC layer is unavailable due to noise, congestion, or some other problem. The DCH3416 stops transmitting data upstream, reports an error to the calling function, and attempts to re-enter the network using the initialization process. 0000 is displayed as the default or if the MAC Abort CNTR is not configured or unknown.		
Socket Port State	The socket mode and activity: <ul style="list-style-type: none"> • UNUSED — The socket is not being used. • OPENED — The socket is open. • READY — The socket is ready to send or receive. • RECEIVING — The socket is receiving data from the application server. • SENDING — The socket is sending data to the application server. • UNKNOWN — The socket state is invalid or unknown. 		

4 DIAGNOSTICS

Keypad — Front Panel Indicators

This diagnostic verifies the functionality of the front panel indicators and the front-panel keypad. Each highlighted character corresponds with a front-panel key press.

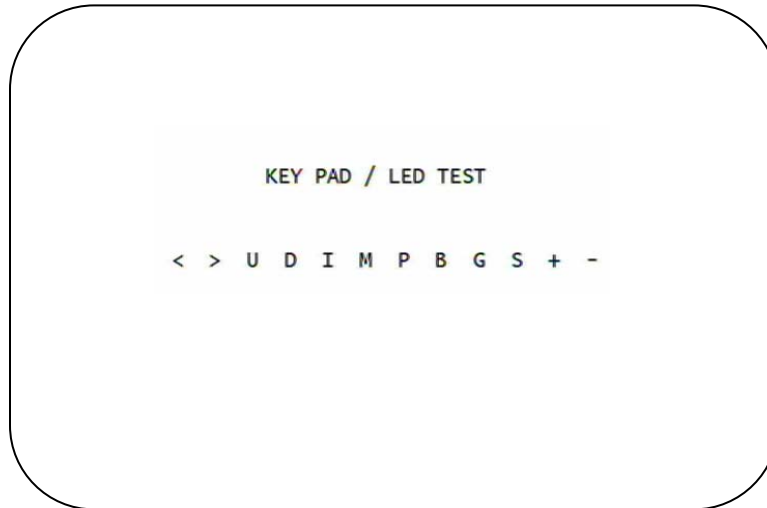



5 TROUBLESHOOTING

Troubleshooting guidelines follow. If problems still occur after performing the diagnostics, call the TRC for assistance as described in the Introduction.

Problem	Possible Solution
The DCH receiver will not power on	<p>The DCH receiver may have received a software update and may not power on while the new software is being installed. Try again in a few minutes.</p> <ul style="list-style-type: none"> • Verify that the AC power cord is connected to the DCH receiver and an AC outlet. Unplug the DCH receiver from the AC outlet, plug it back in, and then press the POWER button. • If the DCH receiver is connected to a switched outlet on another unit, verify that that unit is powered on. Unplug the power cord from the DCH receiver's AC outlet, plug it back in, and then press the POWER button. It is recommended to use an unswitched outlet, if possible. • Press the POWER button on the DCH receiver's front panel instead of the remote control. The batteries in the remote control may be depleted.
The remote control does not work	<ul style="list-style-type: none"> • Verify that the remote control is in "Cable" mode. • Verify that there are no obstructions between the remote control and the DCH receiver. Aim the remote control directly at the DCH receiver front panel, not the TV or VCR. <p>The angle between the remote control and the DCH receiver may be too large. Stand in front of the DCH receiver and not too far to either side.</p> <ul style="list-style-type: none"> • Press and release operation keys one at a time, firmly and deliberately. • Try changing channels using the buttons on the DCH receiver front panel. • Check the batteries in the remote control. Install new batteries if needed.
There is no audio when viewing cable channels	<ul style="list-style-type: none"> • Verify that the mute button on the DCH receiver or the remote control has not been pressed. Press MUTE on the remote control to restore sound. • If the DCH receiver audio output is connected to the TV, verify that the mute button on the TV has not been pressed. • If the DCH receiver audio output is connected to a home theater receiver, verify that the receiver is set to the appropriate input source and the mute button on the receiver has not been pressed. • Verify that you have the correct cables for the audio connections. • Verify that the audio cables are firmly connected between the DCH receiver and the audio playback device (TV, receiver, DVD player, etc.).
There is no audio from the center and/or surround speakers of a home theater receiver connected to the DCH receiver	<p>Not all Dolby® Digital programs feature full 5.1 surround sound. In some cases, the programs may only contain left and right stereo audio.</p> <ul style="list-style-type: none"> • Verify that the S/PDIF cable (coaxial or optical) is firmly connected to the DCH receiver and the home theater receiver. • Verify that the home theater receiver is set to a surround sound audio mode (Dolby Digital, Dolby Pro Logic II®, Dolby Pro Logic®). • Verify that the receiver is properly configured to work with all connected speakers.
There is no video on the TV screen	<ul style="list-style-type: none"> • Verify that the TV is powered on and set to the appropriate input source for the DCH receiver. • Verify that the DCH receiver is powered on and tuned to an authorized cable channel.

5 TROUBLESHOOTING

Problem	Possible Solution
	<ul style="list-style-type: none"> • Verify that all video cables between the DCH receiver and the TV are firmly connected. • Verify that the coaxial cable feed is firmly connected to the DCH receiver and the wall jack. • If the DCH receiver video output is connected to a home theater unit, verify that the home theater unit is powered on and set to the appropriate input source. • If the DCH receiver video output is connected to a TV through an HDMI connection, power off the TV and then power off the DCH receiver. Wait one second and then power on the devices. <p>Not all HDTVs can display every output format (1080i, 720p, 480p, or 480i) available on the DCH receiver. To select a different format:</p> <ul style="list-style-type: none"> • Ensure that your DCH receiver is plugged into a power outlet and is turned off. • Press the MENU key on the front panel. Your settings are displayed on the DCH receiver front panel display. • Press the ▲ and ▼ keys to display the HDMI/YPbPr OUTPUT setting. • Press the ► key to cycle through the available output formats until a picture displays on the TV.
<p>No graphics or program guides appear on the TV screen</p>	<p>If you use the IEEE-1394 connection, on-screen graphics, including closed captions and program guides, are not displayed by the DCH receiver. On-screen graphics and captions may still be overlaid by your TV, if enabled. Alternatively, use HDMI or component video instead.</p>
<p>No closed captions display</p>	<ul style="list-style-type: none"> • Verify on the User Settings menu that closed captions are enabled on the DCH receiver. • Verify that closed captions are enabled on the TV. <p>Note: Closed captioning may not be available on the current program.</p>
<p>There are black bars to the right and left of the picture</p>	<p>Widescreen TVs display 4:3 programs in this format unless set to Stretch. Turn on the 4:3 OVERRIDE feature in the User Settings menu. This enables most widescreen TVs to stretch the video to fill the screen (see your TV manual for information about stretching 4:3 video).</p> <ul style="list-style-type: none"> • If the DCH3416 is connected to a widescreen TV, verify that the TV TYPE is set to 16:9 in the User Settings menu. <p>Many HD programs are broadcast in pillar-box format with black bars to the left and right of the picture. These programs are broadcast in 16:9 HD formats, even though the video is not 16:9.</p>
<p>There are black bars above and below the picture</p>	<p>All 4:3 HDTVs display HD programs in letterbox format (black bars above and below the picture) because of the shape of the display screen.</p> <ul style="list-style-type: none"> • Turn on the 4:3 OVERRIDE feature in the User Settings menu. This enables most standard-screen TVs to display a full screen picture when the DCH3416 is tuned to a 4:3 program. • Set the TV TYPE to 4:3 Pan-Scan. This enables the DCH3416 to remove the black bars above and below the picture when possible. <p>Some SD programs are broadcast in the letterbox format with black bars above and below the picture. Some widescreen TVs offer a zoom feature that may be able to remove the black bars (see your TV manual for information about zooming 4:3 video).</p>

5 TROUBLESHOOTING

Problem	Possible Solution
There are black bars on all four sides of the picture	<p>This may occur on a 4:3 TV if the 4:3 OVERRIDE setting is OFF. To set 4:3 SD programming to fill the screen, depending on the capabilities of the TV, set 4:3 OVERRIDE to 480i or 480p.</p> <p>This may occur on a 16:9 TV if the active video for an SD broadcast is in letterbox format. To confirm, wait for a commercial or look for a graphic, such as a network logo. If the commercial fills the screen from top to bottom, or the graphic appears below the active video, the program is being letterboxed by the broadcaster. You can minimize this by activating the zoom feature on the TV.</p> <p>A broadcaster may include black bars on either side of a widescreen broadcast. This is called a "hybrid" aspect ratio and results in a black border surrounding the video on a 4:3 TV. Because this is part of the broadcast, the DCH3416 cannot correct the video. You may be able to minimize the border using the zoom feature on the TV.</p>
Colors do not appear correctly	<p>Be sure to match up each signal to the same YPbPr connection on the TV. Otherwise, colors will not appear correctly on your TV.</p>
The DCH receiver is making a humming noise.	<p>The DCH3416 includes an integrated hard drive and a fan for cooling. During normal operation, the DCH3416 emits a low humming noise, similar to a personal computer. The noise varies in volume occasionally when the speed of the internal fan adjusts to changes in the temperature around the DCH receiver. Please note the hard drive will stay on even when the DCH3416 is turned off (standby).</p>



MOTOROLA

Motorola, Inc.
101 Tournament Drive
Horsham, PA 19044 U.S.A.

<http://www.motorola.com>

537535-001-b
12/07